



B8 Grab Handle

Large · Surface mount

- Front or rear concealed installation
- Ergonomic, comfortable grip
- High strength, light-weight solution

Material and Finish

Handle: ABS plastic, black
Screws: Steel, zinc plated

Performance Details

Max. static load: 775 N (175 lbf)

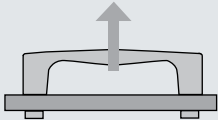

Flammability rating: UL94-HB

Operating temperature range:
-40°C (-40°F) to 60°C (140°F)

Installation Notes

Max. tightening torque of screws:
Rear install concealed only
4.0 N·m (35 in·lbf)

Notes

Bulk packaged

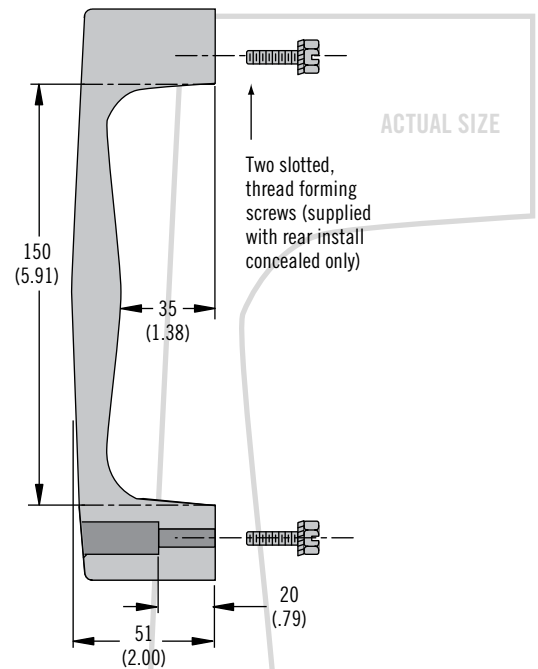
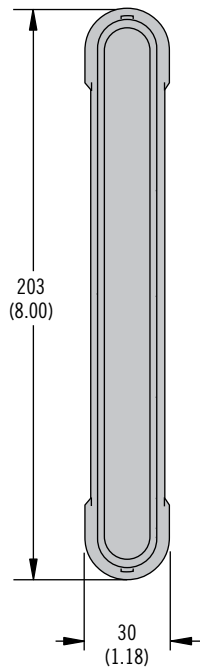

Part Number	
Rear Install Concealed	Front Install Concealed
B8-66-3	B8-63-3

Rear Install Concealed

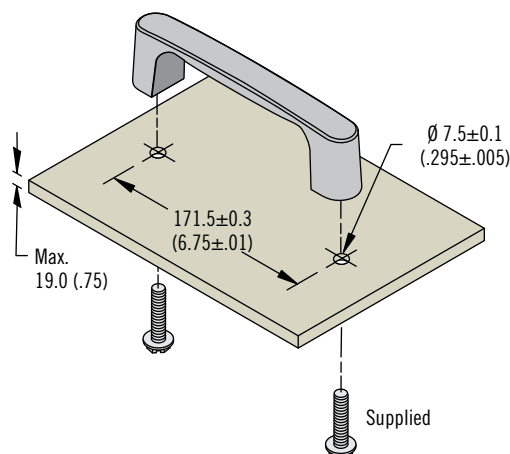

Front Install Concealed

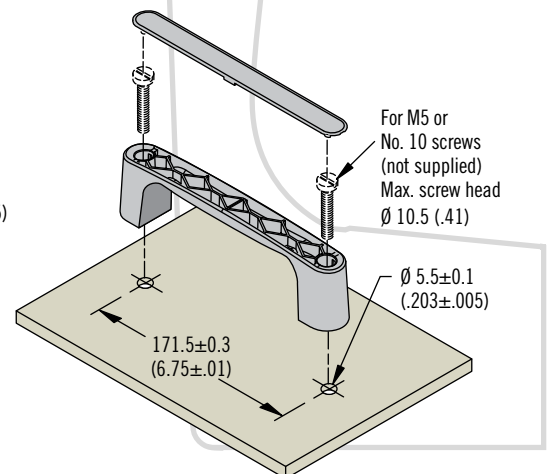

B8 Grab Handle

Small · Surface mount

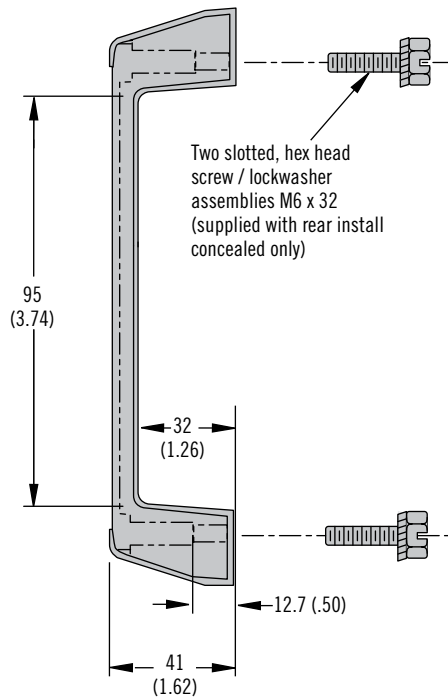
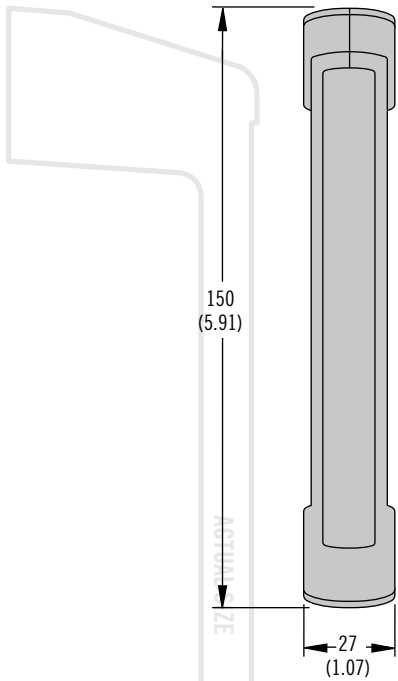

- Front or rear concealed installation
- Light-weight

Material and Finish

Handle: ABS plastic, black
Screws: Steel, zinc plated

Performance Details

Max. static load: 550 N (125 lbf)

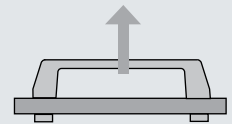

Flammability rating: UL94-HB

Operating temperature range:
-50°C (-60°F) to 60°C (140°F)

Installation Notes

Rear install concealed:
M6 x 32 screw assembly supplied.
Max. tightening torque of screws:
4.0 N·m (35 in·lbf).

For door thickness greater than
16 (.63) calculate screw length
using the following formula:
Door thickness + 16 (.63)

Notes

Bulk packaged

Part Number	
Rear Install Concealed	Front Install Concealed
B8-45-3	B8-43-3

Rear Install Concealed

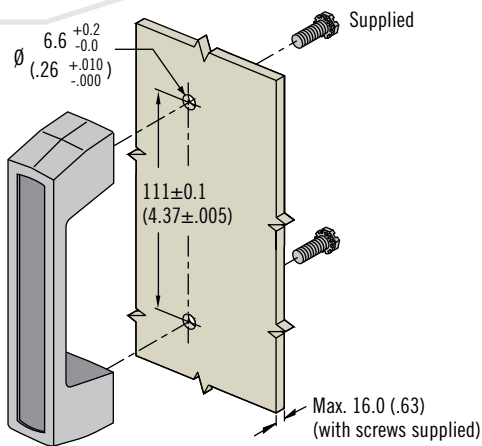

Front Install Concealed

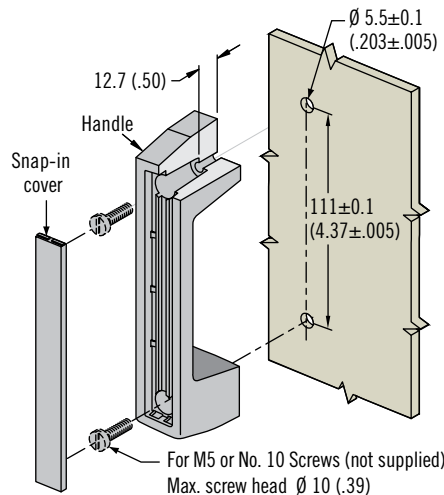

B8-21-404-10
B8-22-401-12
B8-43
B8-43-3
B8-45
B8-45-3
B8-63
B8-631
B8-63-3
B8-63-3-P
B8-634
B8-66
B8-663
B8-66-3
B8-DHAI-140
B8-DHAS-100
B8-DHUA-117-C
B8-DHUA-150-C
B8-DHURH-122
B8-DHURH-150
B8-DHURI-117
B8-DHURI-92
B8-DHURS-92
B8-DHW-160-16
B8-DHWA-100-PC
B8-DHWA-100-STPC
B8-DKCS-40-06-10
B8-DKCS-40-06-20
B8-DKCS-40-06-30
B8-DKCS-40-06-40
B8-DKCS-40-06-70
B8-DPAOS-0545-20
B8-DPAOS-0545-30
B8-DPAOS-0545-40
B8-DPAOS-0545-50
B8-DZAH-195-PC
B8-DZHS-L
B8-DZHS-R
B8-DZWC2-L
B8-DZWC2-R