

PLASTİK ÇEYREK DÖNÜŞLÜ TİP

QUICK RELEASE FASTENERS - QUARTER TURN

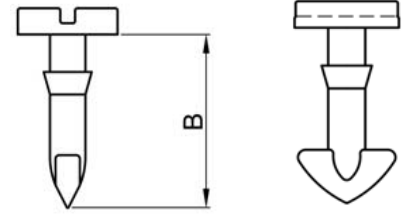

Tip 1 / Type 1



A	B	C	ÜRÜN N. PART N.		
5,6 - 6,4	19,0	3	QTS121		
5,6 - 7,3	17,9	2	QTS122		
7,6 - 8,4	19,6	1	QTS123		
7,6 - 8,4	20,0	2	QTS124		

Saplamalar / Studs

Tip 2 / Type 2

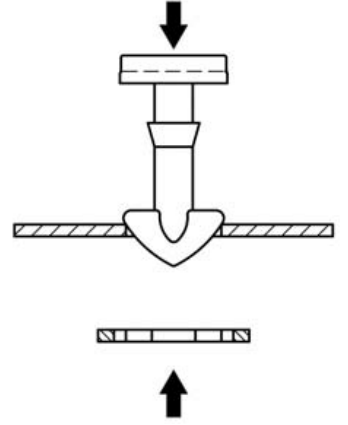
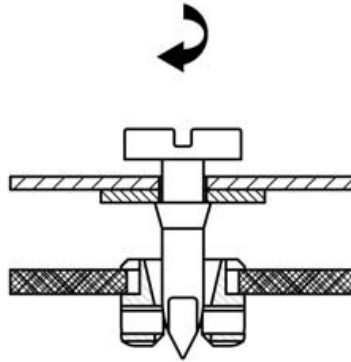

Tip 3 / Type 3

