

CABIN & COCKPIT ENTRY HARDWARE

MG Star Sailor Entry Door Lock

A

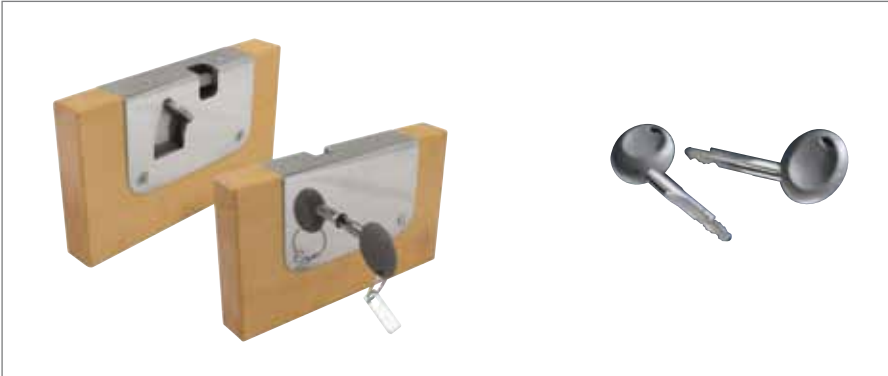

- Suitable for 12mm and 22mm entry door thicknesses
- Provide high-end security with the Star-Lock system's three-axis six-pin tumbler design
- Locks can be matched to other Southco deck latches. Contact Southco Marine for more information

Material and Finish

Lock Case: 316 Stainless Steel
 Internal Components: 316 Stainless Steel
 Star Plug: Brass
 Spring: 316 Stainless Steel
 Screws: 316 Stainless Steel
 Gasket: Rubber (12mm version)

Optional Spacer: 316 Stainless Steel
 Part number: MG-05-115

Use with MG-05-733-24 to enable 10mm Door thickness
 Use with MG-05-736-24 to enable 20mm Door thickness

Assembly

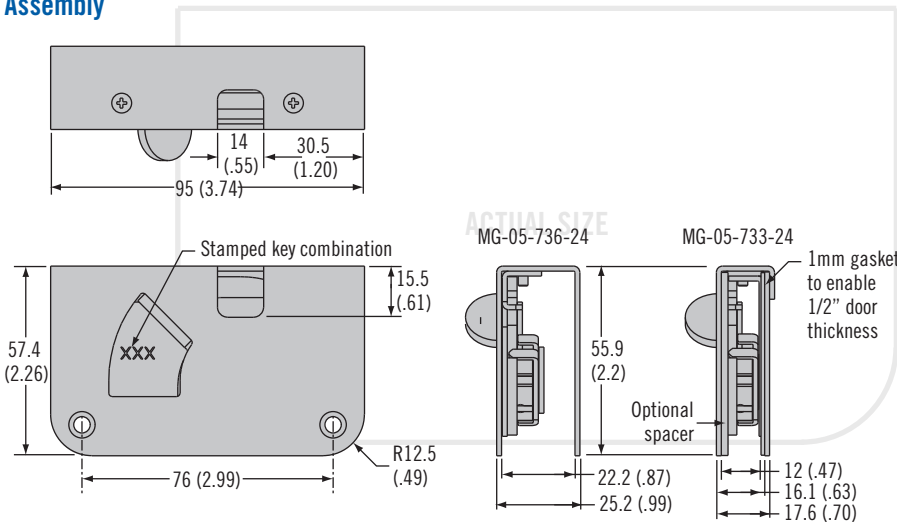

Panel Preparation

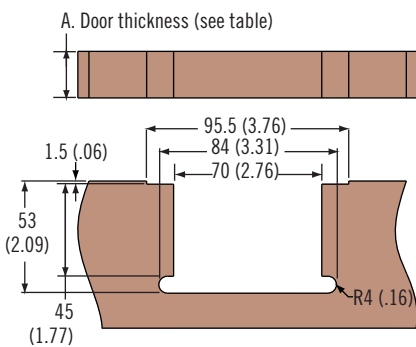

Installation

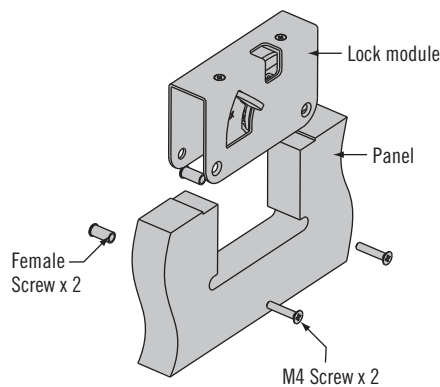

Optional Spacer (2mm)

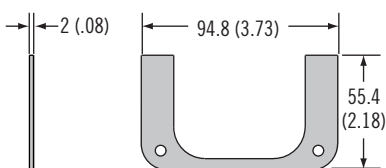

Part Number Selection

MG - 05 - 73 C - 24

C Door Thickness (A)
3 12mm (.5)
6 22mm (.86)



CABIN & COCKPIT ENTRY HARDWARE

Striker Alignment

A

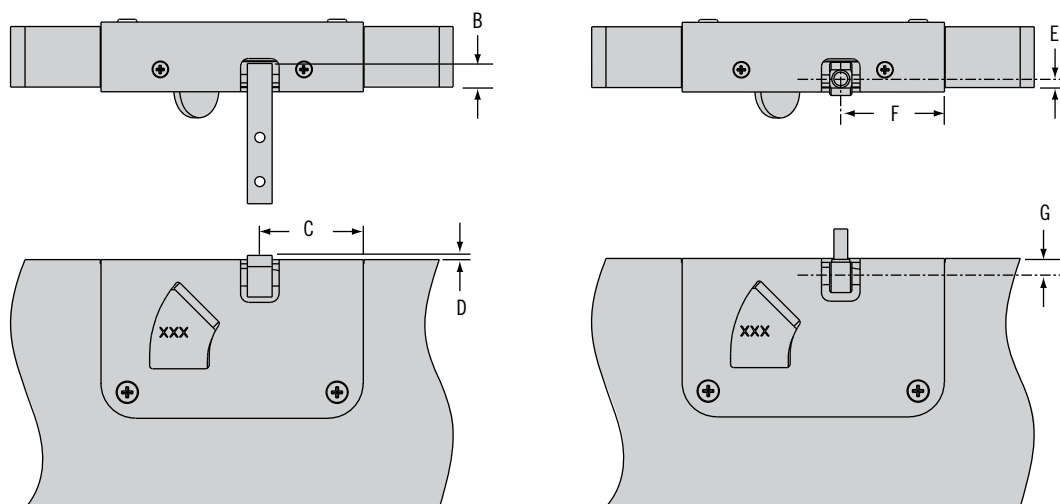

Strikers

Striker:

Anodized Aluminium: MG-90-102-60

Anodized Black: MG-90-102-50

B: 8.6 ± 1.3 (.34) \pm (.51)

C: 37.5 ± 2.5 (1.48) \pm (.09)

D: 2.0 ± 1.2 (.80) \pm (.04)

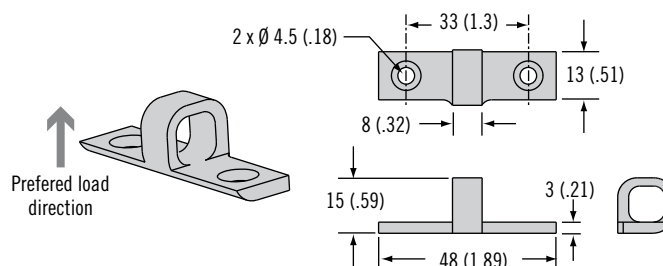

P-Striker:

Anodized Aluminium: MG-90-105-50

Anodized Black: MG-90-105-61

B: 8.6 ± 1.3 (.34) \pm (.51)

C: 37.5 ± 2.5 (1.48) \pm (.09)

D: 2.0 ± 1.2 (.80) \pm (.04)

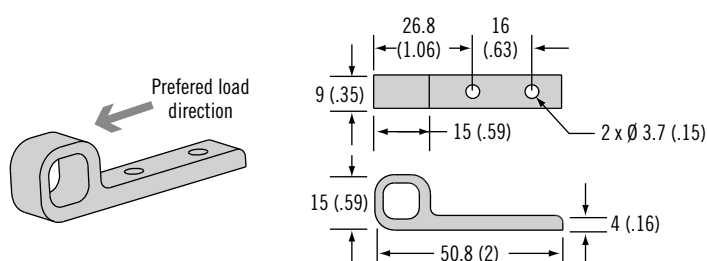

Eyelet Striker:

Stainless Steel: MG-90-103-24

B: 37.5 ± 2.5 (1.48) \pm (.09)

E: 2.9 ± 1 (.11) \pm (.03)

F: 37.5 ± 2 (1.48) \pm (.07)

G: $5.8 \pm .4$ (.23) \pm (.01)

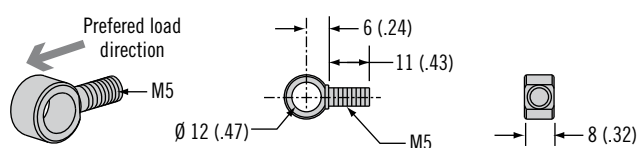

CABIN & COCKPIT ENTRY HARDWARE

MG Secure Entry Door Lock

A

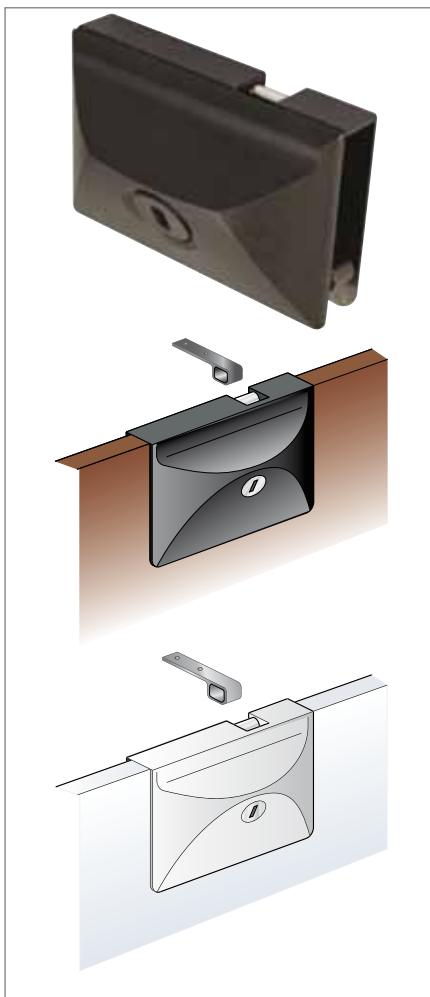

DOOR THICKNESS: 12mm (7/16") (or 10mm (3/8") with optional spacer)

The Secure is designed for both swinging and sliding doors. It can be used on acrylic or wood doors, bi-fold doors, hatches, and companionway drop-in boards. The Secure is easy to install, since no fasteners are required - simply snap the Secure over the door edge.

- Offered in all corrosion-resistant materials, including Polyamide, Stainless Steel, and Brass
- Outside keylocking with interior sliding privacy lock
- Supplied with striker and two keys

Available Options:

Finish: White or black polyamide case available.

Accessories:

Locking: Optional black day key available.

Spacer: Optional spacer available to accept a 10mm (3/8") door thickness.

Striker: Numerous strikers available in clear or black anodised aluminum or stainless steel.

Different shapes available.

For spare keys please contact Southco Marine

C

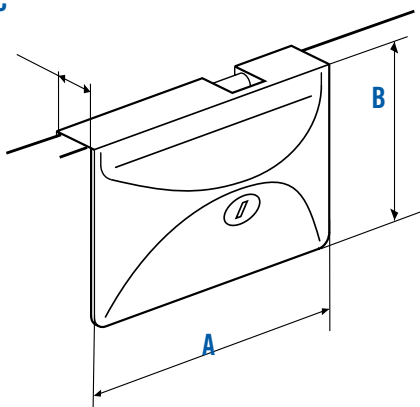





	Imperial		Metric
	Nominal	Decimal	
A	3 27/64	3.43	87
B	2 11/64	2.17	55
C	15/32	.47	12

SECURE PART NUMBERS

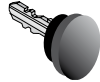
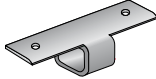
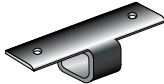
	Black	White
With P-striker and two keys	MG-01-110-50	MG-01-110-70

ACCESSORIES

Day key, black		MF-96-XXX-41
Striker, anodized aluminum		MG-90-102-60
Striker, anodized black		MG-90-102-50
Eyelet striker, stainless steel		MG-90-103-24
Eyelet striker, offcenter, stainless steel		MG-90-104-24
Spacer for 10mm (3/8") door thickness		MG-92-100-50



CABIN & COCKPIT ENTRY HARDWARE

Panel Preparations

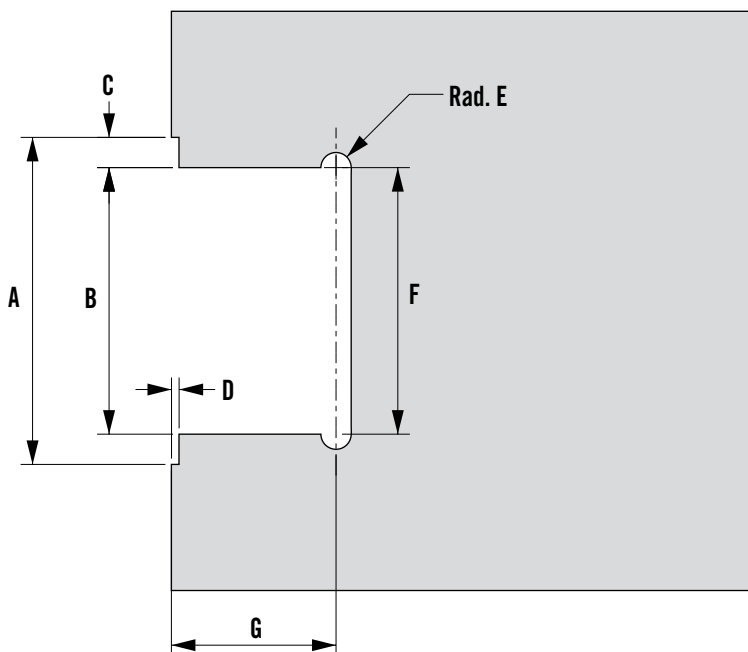

	Imperial		Metric
	Nominal	Decimal	
A	3 13/32	3.406	86.5
B	2 25/32	2.776	70.5
C	5/16	.315	8
D	5/64	.079	2
E	5/32	.156	4
F	2 27/32	2.835	72
G	1 23/32	1.713	43.5

- How to determine your key combination

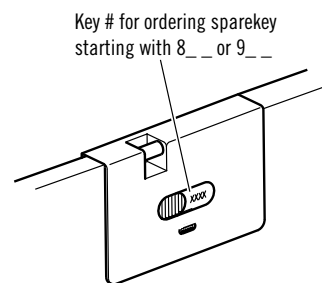

Installation

1

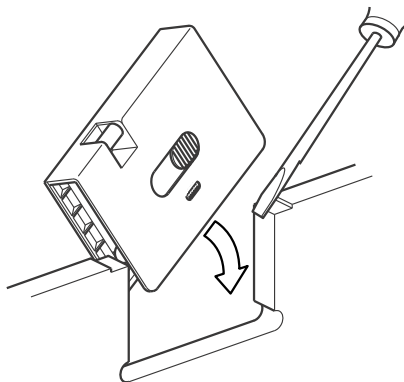

2

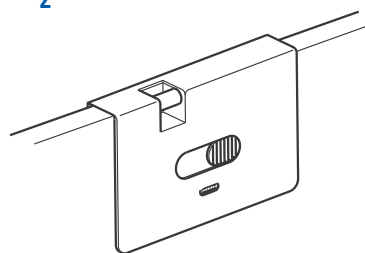

3

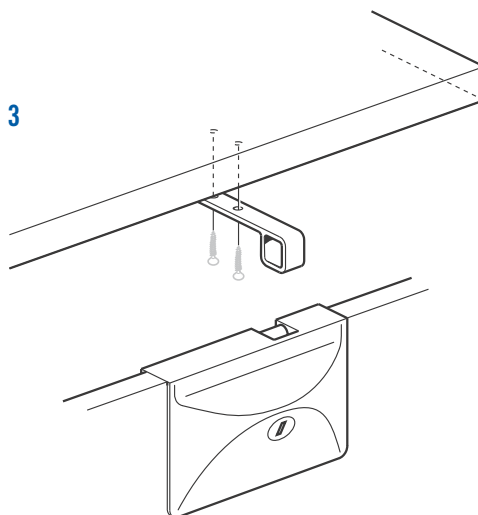

CABIN & COCKPIT ENTRY HARDWARE

MG L-Star Entry Door Lock

A

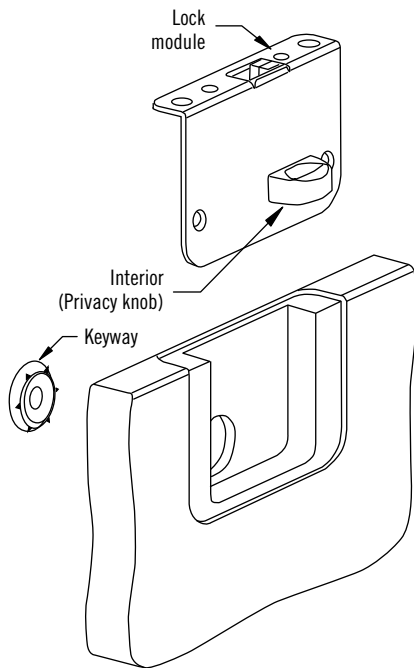

Part number

MG-03-630-24

Gain more stylish and more secure locking performance for specialised door applications in sail or motor boat and yacht construction. The Mobella L-Star is ideal for washboard entry ways – even those angled up to 7° beyond perpendicular – as well as for bi-fold doors and other cabin or entry doors. The security of the Star-Lock mechanism adds peace of mind, while all-marine-grade construction ensures robust performance.

- Enhance high-end security with the hard-to-compromise Star-Lock three-axis six-pin tumbler design
- Locks can be matched to other Southco deck latches
Contact Southco Marine for more information
- Simplify installation with slip-in mounting on the back edge of the door
- Satisfy customer preferences with a variety of decor options
- including diamond brass, polished chrome and satin finishes
- Accommodate door thicknesses from 19 mm to 45 mm without a recess, and engage with overhead hatches of 10 mm or thicker

Panel Preparation

Minimum panel thickness A 20 mm (0.71), Maximum panel thickness 44 mm (1.75).

No mounting hardware included.

Flush mount panel preparation shown

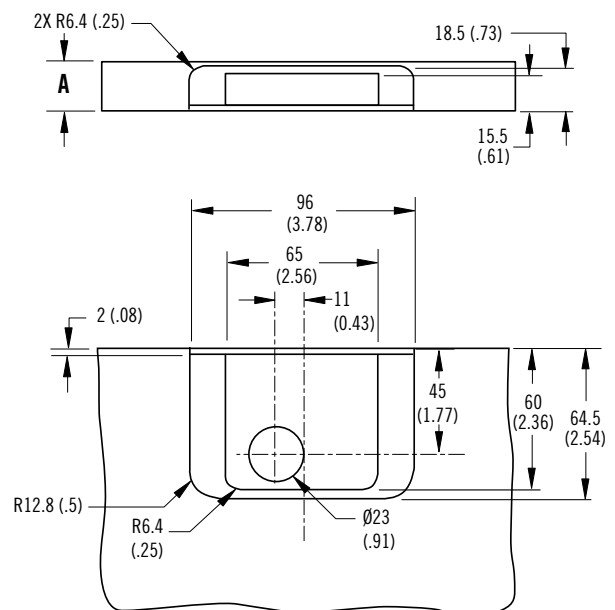
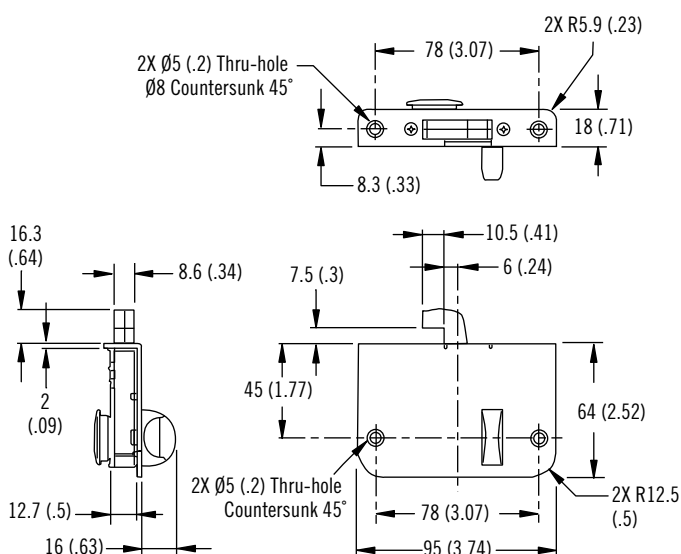

CABIN & COCKPIT ENTRY HARDWARE

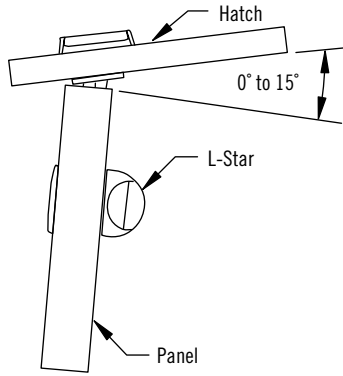

Striker

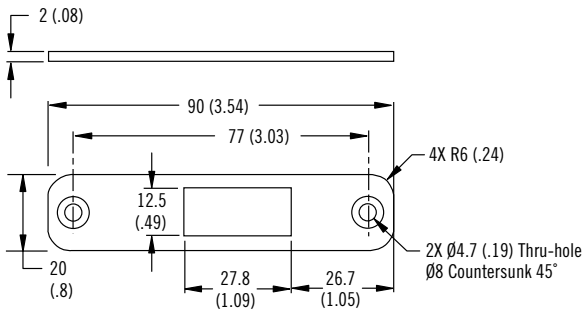

Striker Part number

MG-90-300-24

Panel Preparation

Minimum panel thickness without recess 19 (.75). Angle range between hatch and panel -7° to +7°. No mounting hardware supplied.

Flush mount panel preparation shown

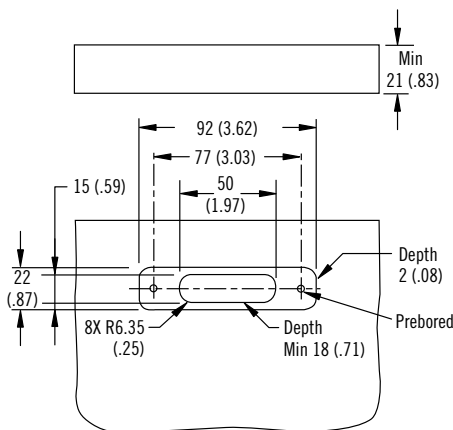

Striker Hood

The Striker Hood is designed for thin panels, or where the panel may not be suitable to directly attach the striker. Note: A striker must be used with the Striker Hood.

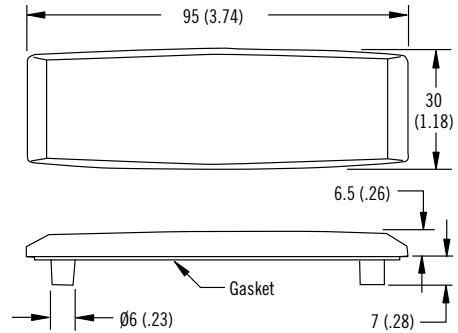

Striker Hood Part number

MG-90-330-24

Panel Preparation

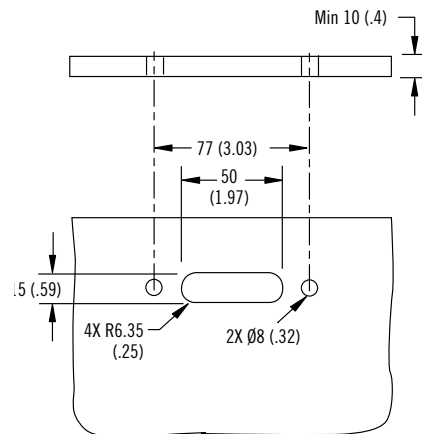

CABIN & COCKPIT ENTRY HARDWARE

MG Single Star Entry Door Lock

A



The Mobella Single Star-Lock provides the flexibility and functionality of a deadbolt that can be installed alone or combined with another latch mechanism for cabin doors, washboard doors, and other door security. By combining reliable Star-Lock performance, all-marine-grade construction, and a clean look with multiple keyhole finish options, it offers the perfect blend of robustness and style for sail or motor boat and yacht applications.

- Enhance high-end security with the hard-to-compromise Star-Lock three-axis six-pin tumbler design
- Locks can be matched to other Southco deck latches
Contact Southco Marine for more information
- Mortise mount design provides a clean appearance
- Satisfy customer preferences with a variety of decor options – including diamond brass, polished chrome and satin finishes
- Accommodate door thicknesses ranging from 22 mm to 45 mm

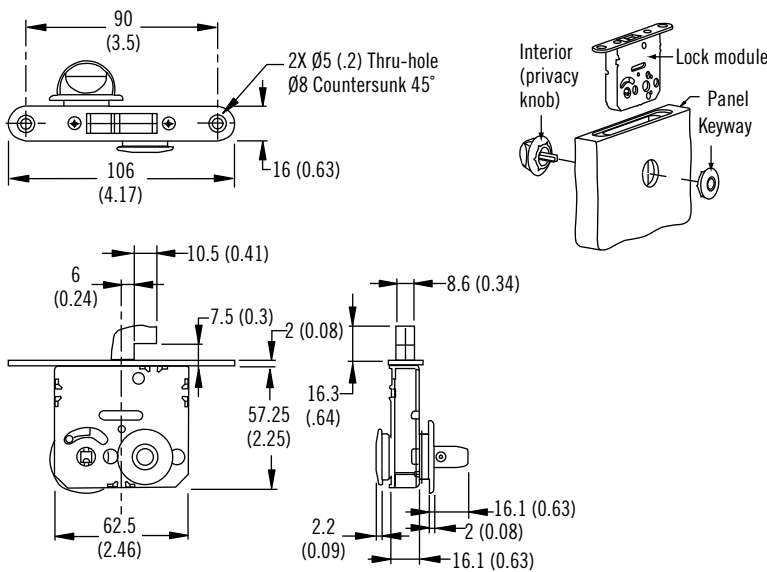

Panel Preparation

*see part number table

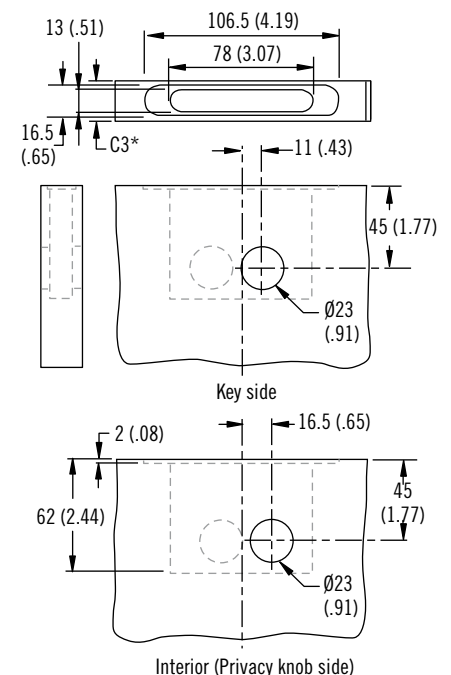

How to order Single Star

Part number formula MG-04-53C ₃ -FF		
DOOR THICKNESS		
C ₃	0	22-30mm (7/8-1 3/16")
	1	28-37mm (1 1/8-1 1/2")
	2	36.5-45mm (1 7/16-1 3/4")
FINISH Handle/Privacy/Escutcheons		
FF	10	Chrome
	20	Satin (matte chrome)
	40	Diamond brass



CABIN & COCKPIT ENTRY HARDWARE

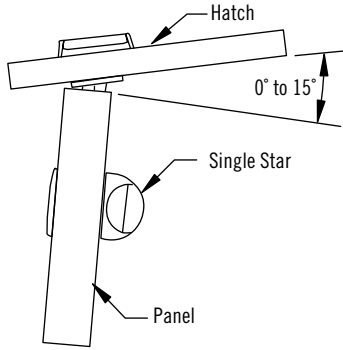

Striker

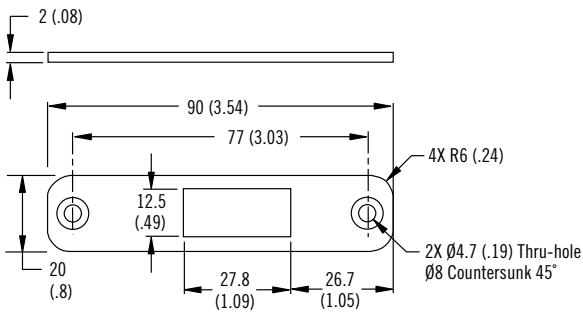

Striker Part number

MG-90-300-24

Panel Preparation

Minimum panel thickness without recess 19 (.75). Angle range between hatch and panel -7° to $+7^\circ$. No mounting hardware supplied.

Flush mount panel preparation shown

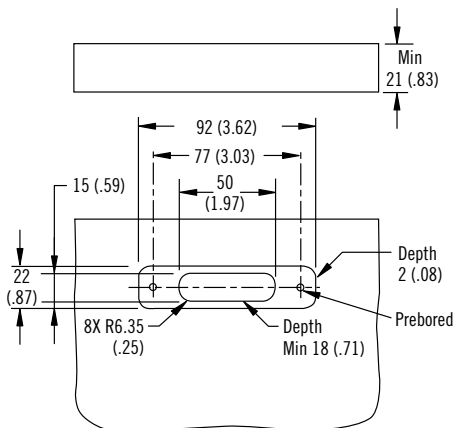

Striker Hood

The Striker Hood is designed for thin panels, or where the panel may not be suitable to directly attach the striker. Note: A striker must be used with the Striker Hood.

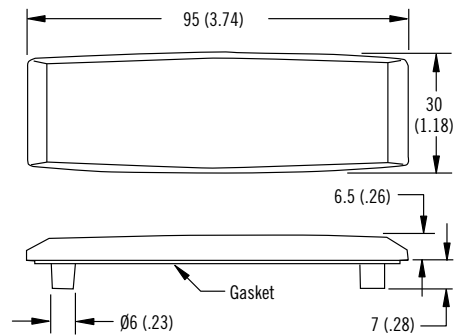

Striker Hood Part number

MG-90-330-24

Panel Preparation

