

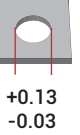
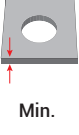
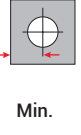

**Malzeme / Material :** 300 Serisi Paslanmaz Çelik / 300 Series Stainless Steel

Ölçülendirme / Dimensions								Kuvvet / Forces		Ürün / Product
Çap Diameter		Boy Length ±0.4mm L			B ±0.13	C -0.13	H Nom.	D ±0.25	Max. Nut Tightening Torque Max. Somun Sıkma Torku (N-m)	
M3X0.5	4.22	3	1	6.0	3.2	4.2	4.8	-	0.44	04.SOS00.M03003
		4								04.SOS00.M03004
		6								04.SOS00.M03006
		8								04.SOS00.M03008
		10								04.SOS00.M03010
		12								04.SOS00.M03012
		14								04.SOS00.M03014
		16								04.SOS00.M03016
		18								04.SOS00.M03018

\* Tüm ölçüler mm cinsindedir. / All dimensions are in mm

\* Tüm boy ölçülerinde [+0,1/-0,5] mm tolerans değeri olasıdır. / A tolerance value of [+0,1/-0,5] mm is possible for all length dimensions

\* 1,5 mm veya daha az malzeme kalınlığı için öerste bir havşa deliği gereklidir. / For material thickness of 1.5mm or less, a countersunk hole is needed in the anvil.



\* 1,5 mm veya daha fazla malzeme kalınlığı için öerste bir geçiş deliği gereklidir. / For material thickness of 1.5mm or more, a through-hole is needed in the anvil

\* Uygulama videosu için QR kodu okutun. / Scan the QR code for the application video.

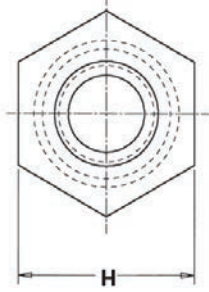
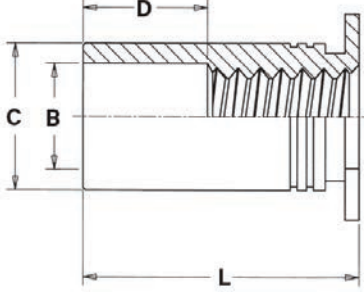

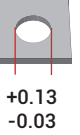
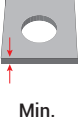
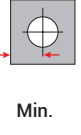

**Malzeme / Material :** 300 Serisi Paslanmaz Çelik / 300 Series Stainless Steel

Ölçülendirme / Dimensions									Kuvvet / Forces	Ürün / Product
Çap Diameter	 +0.13 -0.03	Boy Length ±0.4mm L	 Min.	 Min.	B ±0.13	C -0.13	H Nom.	D ±0.25	Max. Nut Tightening Torque Max. Somun Sıkma Torku (N-m)	 04.SOS00
M3.5X0.6	5.41	3	1	6.0	3.9	5.39	6.4	-	0.73	04.SOS00.M03503
		4								04.SOS00.M03504
		6								04.SOS00.M03506
		8								04.SOS00.M03508
		10								04.SOS00.M03510
		12								04.SOS00.M03512
		14								04.SOS00.M03514
		16								04.SOS00.M03516
		18								04.SOS00.M03518
		20								04.SOS00.M03520
		22								04.SOS00.M03522
		25								04.SOS00.M03525

\* Tüm ölçüler mm cinsindedir. / All dimensions are in mm

\* Tüm boy ölçülerinde [+0,1/-0,5] mm tolerans değeri olasıdır. / A tolerance value of [+0,1/-0,5] mm is possible for all length dimensions

\* 1,5 mm veya daha az malzeme kalınlığı için öerste bir havşa deliği gereklidir. / For material thickness of 1.5mm or less, a countersunk hole is needed in the anvil.



\* 1,5 mm veya daha fazla malzeme kalınlığı için öerste bir geçiş deliği gereklidir. / For material thickness of 1.5mm or more, a through-hole is needed in the anvil

\* Uygulama videosu için QR kodu okutun. / Scan the QR code for the application video.

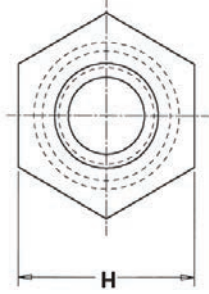
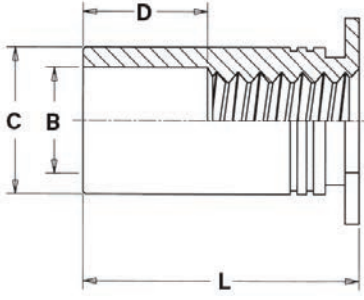

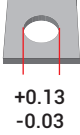
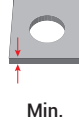
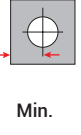

**Malzeme / Material :** 300 Serisi Paslanmaz Çelik / 300 Series Stainless Steel

Ölçülendirme / Dimensions									Kuvvet / Forces	Ürün / Product
Çap Diameter	 +0.13 -0.03	Boy Length ±0.4mm L	 Min.	 Min.	B ±0.13	C -0.13	H Nom.	D ±0.25	Max. Nut Tightening Torque Max. Somun Sıkma Torku (N-m)	 04.SOS00
M4X0.7	7.14	3	1.27	8.0	4.8	7.12	7.9	-	1.60	04.SOS00.M04003
		4								04.SOS00.M04004
		6								04.SOS00.M04006
		8								04.SOS00.M04008
		10								04.SOS00.M04010
		12								04.SOS00.M04012
		14								04.SOS00.M04014
		16								04.SOS00.M04016
		18								04.SOS00.M04018
		20								04.SOS00.M04020
		22								04.SOS00.M04022
		25								04.SOS00.M04025

\* Tüm ölçüler mm cinsindedir. / All dimensions are in mm

\* Tüm boy ölçülerinde [+0,1/-0,5] mm tolerans değeri olasıdır. / A tolerance value of [+0,1/-0,5] mm is possible for all length dimensions

\* 1,5 mm veya daha az malzeme kalınlığı için örste bir havşa deliği gereklidir. / For material thickness of 1.5mm or less, a countersunk hole is needed in the anvil.



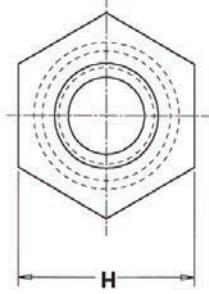
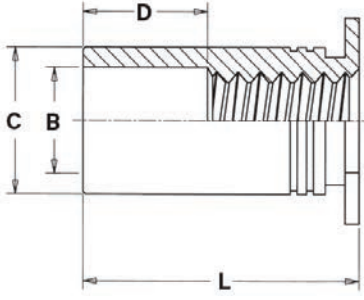

\* 1,5 mm veya daha fazla malzeme kalınlığı için örste bir geçiş deliği gereklidir. / For material thickness of 1.5mm or more, a through-hole is needed in the anvil

\* Uygulama videosu için QR kodu okutun. / Scan the QR code for the application video.



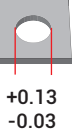

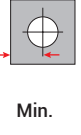
**Malzeme / Material :** 300 Serisi Paslanmaz Çelik / 300 Series Stainless Steel

Ölçülendirme / Dimensions									Kuvvet / Forces	Ürün / Product
Çap Diameter	 +0.13 -0.03	Boy Length ±0.4mm L	 Min.	 Min.	B ±0.13	C -0.13	H Nom.	D ±0.25	Max. Nut Tightening Torque Max. Somun Sıkma Torku (N-m)	 04.SOS00
M5X0.8	7.14	3	1.27	8.0	5.35	7.12	7.9	-	2.88	04.SOS00.M05003
		4								04.SOS00.M05004
		6								04.SOS00.M05006
		8								04.SOS00.M05008
		10								04.SOS00.M05010
		12								04.SOS00.M05012
		14								04.SOS00.M05014
		16								04.SOS00.M05016
		18								04.SOS00.M05018
		20								04.SOS00.M05020
		22								04.SOS00.M05022
		25								04.SOS00.M05025

\* Tüm ölçüler mm cinsindedir. / All dimensions are in mm

\* Tüm boy ölçülerinde [+0,1/-0,5] mm tolerans değeri olasıdır. / A tolerance value of [+0,1/-0,5] mm is possible for all length dimensions

\* 1,5 mm veya daha az malzeme kalınlığı için örste bir havşa deliği gereklidir. / For material thickness of 1.5mm or less, a countersunk hole is needed in the anvil.

\* 1,5 mm veya daha fazla malzeme kalınlığı için örste bir geçiş deliği gereklidir. / For material thickness of 1.5mm or more, a through-hole is needed in the anvil

\* Uygulama videosu için QR kodu okutun. / Scan the QR code for the application video.

