





Malzeme / Material : Isıl İşlem Görmüş Karbon Çelik Çinko Kaplama / Heat-Treated Carbon Steel Zinc Plated

Ölçülendirme / Dimensions					Kuvvet / Forces			Ürün / Product	
Çap Diameter	 +0.13 -0.03	Boy Length +0.05 -0.13 L	 Min.	 Min.	C -0.13	H Nom.	F Min.	Max. Nut Tightening Torque Max. Somun Sıkma Torku (N-m)	 04.BSO00
M3X0.5	4.22	6	1	6.0	4.2	4.8	3.2	0.55	04.BSO00.M03006
		8					4		04.BSO00.M03008
		10					5		04.BSO00.M03010
		12					6.5		04.BSO00.M03012
		14					9.5		04.BSO00.M03014
		16					04.BSO00.M03016		
		18					04.BSO00.M03018		
		20					04.BSO00.M03020		
		22					04.BSO00.M03022		
		25					04.BSO00.M03025		

* Tüm ölçüler mm cinsindedir. / All dimensions are in mm

* Tüm boy ölçülerinde [+0,1/-0,5] mm tolerans değeri olasıdır. / A tolerance value of [+0,1/-0,5] mm is possible for all length dimensions

* 1,5 mm veya daha az malzeme kalınlığı için örste bir havşa deliği gereklidir. / For material thickness of 1.5mm or less, a countersunk hole is needed in the anvil.



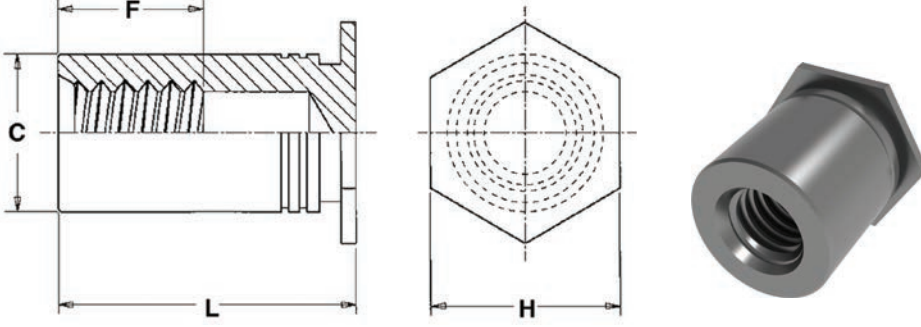

* 1,5 mm veya daha fazla malzeme kalınlığı için örste bir geçiş deliği gereklidir. / For material thickness of 1.5mm or more, a through-hole is needed in the anvil

* Uygulama videosu için QR kodu okutun. / Scan the QR code for the application video.





Malzeme / Material : Isıl İşlem Görmüş Karbon Çelik Çinko Kaplama / Heat-Treated Carbon Steel Zinc Plated

Ölçülendirme / Dimensions						Kuvvet / Forces		Ürün / Product	
Çap Diameter	 +0.13 -0.03	Boy Length +0.05 -0.13 L	 Min.	 Min.	C -0.13	H Nom.	F Min.	Max. Nut Tightening Torque Max. Somun Sıkma Torku (N-m)	 04.BSO00
M3.5X0.6	5.41	6	1	6.8	5.39	6.4	3.2	0.91	04.BSO00.M03506
		8					4		04.BSO00.M03508
		10					5		04.BSO00.M03510
		12					6.5		04.BSO00.M03512
		14					9.5		04.BSO00.M03514
		16					04.BSO00.M03516		
		18					04.BSO00.M03518		
		20					04.BSO00.M03520		
		22					04.BSO00.M03522		
		25					04.BSO00.M03525		

* Tüm ölçüler mm cinsindedir. / All dimensions are in mm

* Tüm boy ölçülerinde [+0,1/-0,5] mm tolerans değeri olasıdır. / A tolerance value of [+0,1/-0,5] mm is possible for all length dimensions

* 1,5 mm veya daha az malzeme kalınlığı için örste bir havşa deliği gereklidir. / For material thickness of 1.5mm or less, a countersunk hole is needed in the anvil.



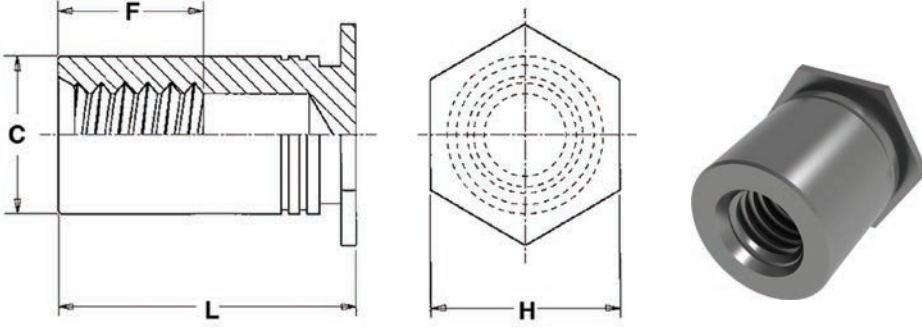

* 1,5 mm veya daha fazla malzeme kalınlığı için örste bir geçiş deliği gereklidir. / For material thickness of 1.5mm or more, a through-hole is needed in the anvil

* Uygulama videosu için QR kodu okutun. / Scan the QR code for the application video.





Malzeme / Material : Isıl İşlem Görmüş Karbon Çelik Çinko Kaplama / Heat-Treated Carbon Steel Zinc Plated

Ölçülendirme / Dimensions						Kuvvet / Forces		Ürün / Product	
Çap Diameter	 +0.13 -0.03	Boy Length +0.05 -0.13 L	 Min.	 Min.	C -0.13	H Nom.	F Min.	Max. Nut Tightening Torque Max. Somun Sıkma Torku (N-m)	 04.BSO00
M4x0.7	7.14	6	1.27	8.0	7.12	7.9	3.2	2.0	04.BSO00.M04006
		8					4		04.BSO00.M04008
		10					5		04.BSO00.M04010
		12					6.5		04.BSO00.M04012
		14					9.5		04.BSO00.M04014
		16					04.BSO00.M04016		
		18					04.BSO00.M04018		
		20					04.BSO00.M04020		
		22					04.BSO00.M04022		
		25					04.BSO00.M04025		

* Tüm ölçüler mm cinsindedir. / All dimensions are in mm

* Tüm boy ölçülerinde [+0,1/-0,5] mm tolerans değeri olasıdır. / A tolerance value of [+0,1/-0,5] mm is possible for all length dimensions

* 1,5 mm veya daha az malzeme kalınlığı için örste bir havşa deliği gereklidir. / For material thickness of 1.5mm or less, a countersunk hole is needed in the anvil.



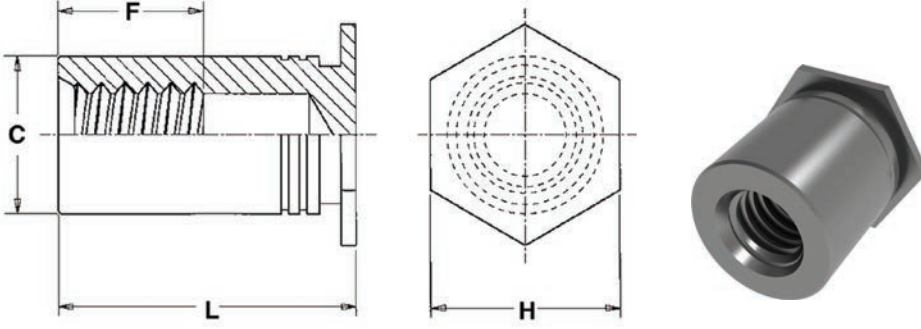

* 1,5 mm veya daha fazla malzeme kalınlığı için örste bir geçiş deliği gereklidir. / For material thickness of 1.5mm or more, a through-hole is needed in the anvil

* Uygulama videosu için QR kodu okutun. / Scan the QR code for the application video.





Malzeme / Material : Isıl İşlem Görmüş Karbon Çelik Çinko Kaplama / Heat-Treated Carbon Steel Zinc Plated

Ölçülendirme / Dimensions						Kuvvet / Forces		Ürün / Product	
Çap Diameter	 +0.13 -0.03	Boy Length +0.05 -0.13 L	 Min.	 Min.	C -0.13	H Nom.	F Min.	Max. Nut Tightening Torque Max. Somun Sıkma Torku (N-m)	 04.BSO00
M5x0.8	7.14	6	1.27	8.0	7.12	7.9	3.2	3.6	04.BSO00.M05006
		8					4		04.BSO00.M05008
		10					5		04.BSO00.M05010
		12					6.5		04.BSO00.M05012
		14					9.5		04.BSO00.M05014
		16					04.BSO00.M05016		
		18					04.BSO00.M05018		
		20					04.BSO00.M05020		
		22					04.BSO00.M05022		
		25					04.BSO00.M05025		

* Tüm ölçüler mm cinsindedir. / All dimensions are in mm

* Tüm boy ölçülerinde [+0,1/-0,5] mm tolerans değeri olasıdır. / A tolerance value of [+0,1/-0,5] mm is possible for all length dimensions

* 1,5 mm veya daha az malzeme kalınlığı için örste bir havşa deliği gereklidir. / For material thickness of 1.5mm or less, a countersunk hole is needed in the anvil.

* 1,5 mm veya daha fazla malzeme kalınlığı için örste bir geçiş deliği gereklidir. / For material thickness of 1.5mm or more, a through-hole is needed in the anvil

* Uygulama videosu için QR kodu okutun. / Scan the QR code for the application video.

