

A5 Modular System

Actuator plates



Actuator Plate

A5-90-101-11

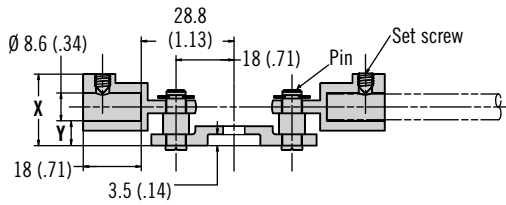
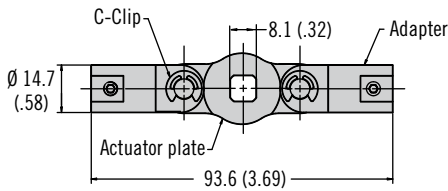

A5-90-301-11

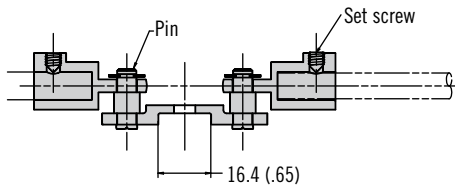
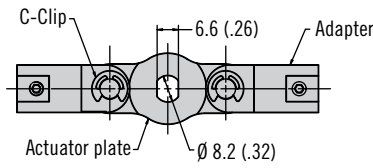

Part Number	X	Y
A5-90-101-11	22.2 (0.87)	4.7 (0.18)
A5-90-104-11	25.2 (0.99)	7.7 (0.30)

A5-90-401-11 (Short Cam)

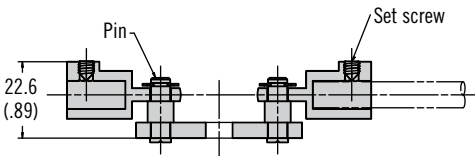
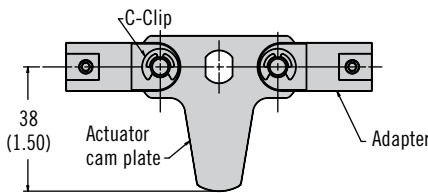

A5-90-501-11 (Long Cam)

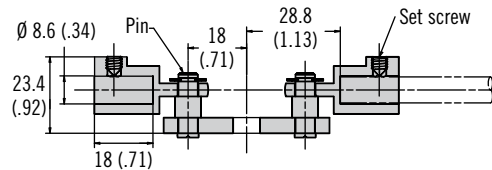
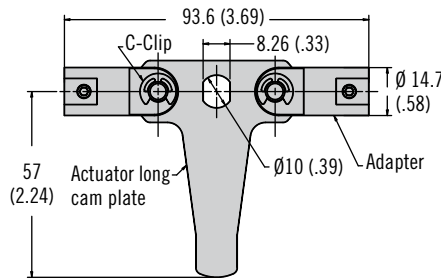

Actuator Plate Part Number						
Operating Latch Families	E5-5	E5-6	E5-9	H3-50	H3-60	62 Series M8 threaded shaft
	Pages 86 - 95			Pages 112 - 113		Pages 68 - 69
Actuator Plate Part Number	A5-90-101-11			A5-90-301-11	A5-90-401-11	A5-90-501-11

- Modular actuators to suit multiple latch families using A5 modular rods

Material and Finish

Zinc alloy, steel, zinc plated and stainless steel set screw

To Select Correct Actuator:

1. Choose actuator plate to match latch family (one per latch required)
2. Order rods and rod guides from page 264

Part Number

Actuator plate see table

Rods (see page 264)

Rod guides (see page 264)



A5 Modular System

Rods and rod guides

• Modular rod and rod guides

Material and Finish

Rods: Aluminum or steel, zinc plated
 Rod rollers: Glass-filled nylon, black
 Rod guides: Glass-filled nylon, black with steel, zinc plated hardware

To Select Correct Assembly:

1. Choose actuator plate to match latch family or linear actuator and 2 adaptors
2. Order rod guides (2 per assembly).
 Fixed rod guide recommended for fixed point rod.
 Adjustable rod guide recommended for rod roller assembly.
3. Order rods (2 per assembly)

Part Number

Order rod and rod guide separately see tables

Rods

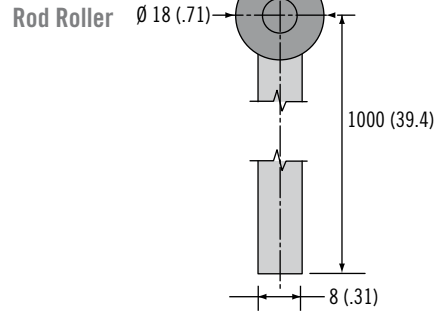

Fixed Point Rod

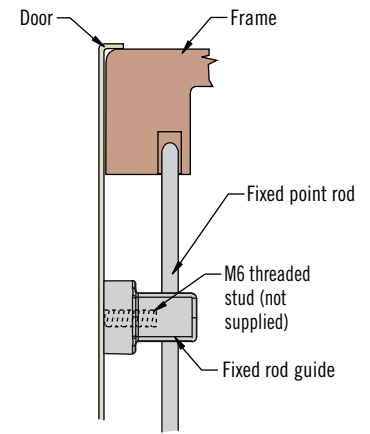
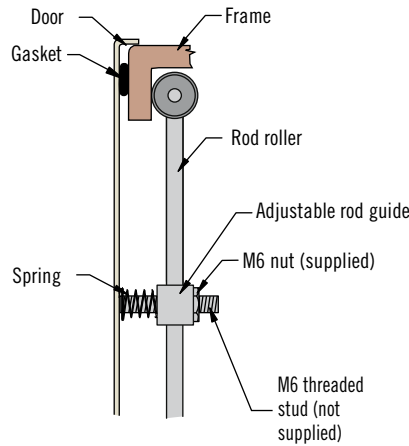
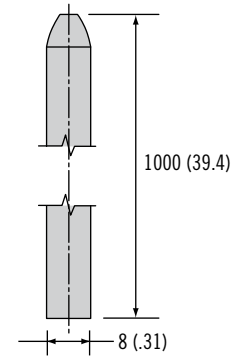

Rod Roller Steel Part Number
A5-56-1000-21

Material	Fixed Point Rod Part Number
Aluminum	A5-55-1000-10
Steel	A5-55-1000-11

Rod Guides

Adjustable

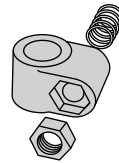
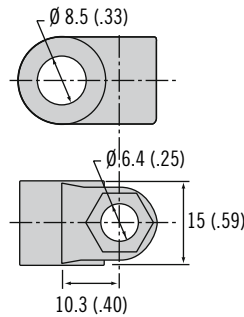

Fixed

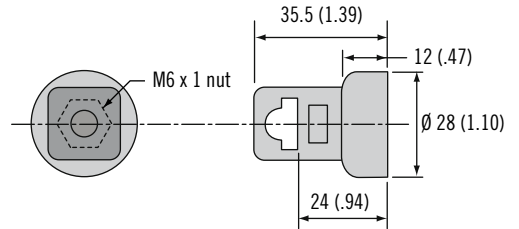

Adjustable Rod Guide Part Number (includes 2 rod guides, 2 springs and 2 M6 nuts)
A5-87-401

Fixed Rod Guide Part Number (one piece supplied)
A5-81-301-71

Other options available. For complete details on variety, part numbers, installation and specification, go to



www.southco.com/A5

Dimensions in millimeters (inch) unless otherwise stated

Linear Actuator Assembly

(adjustable with rod roller shown)

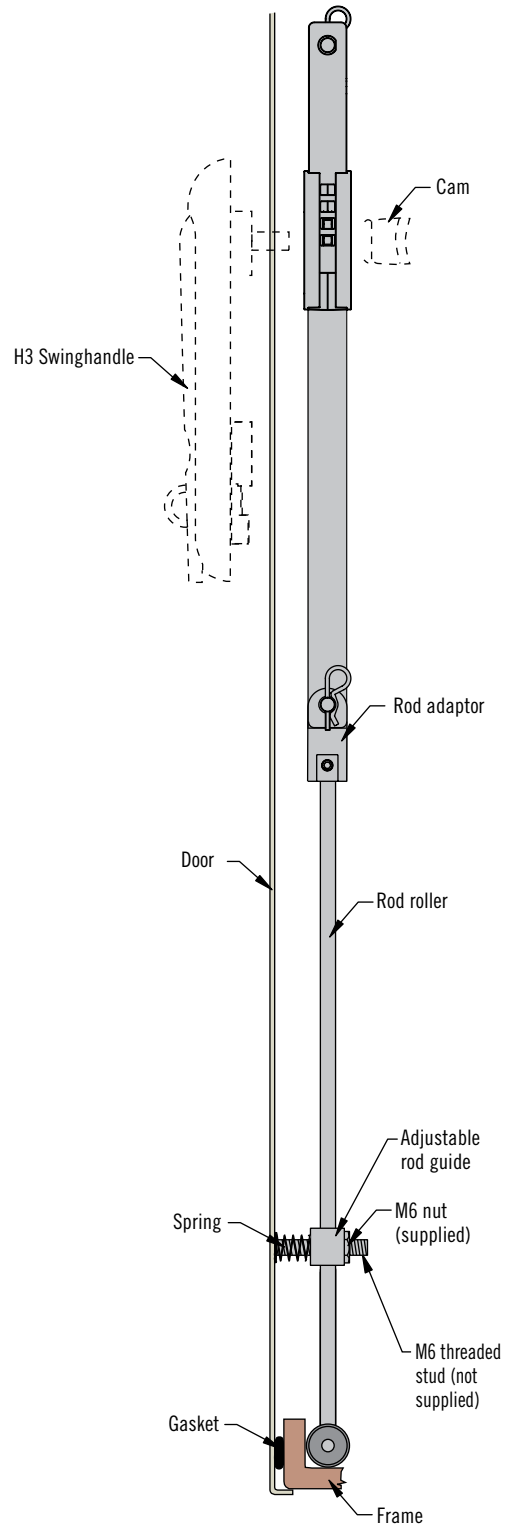

Actuator Plate Assembly

(fixed point shown)

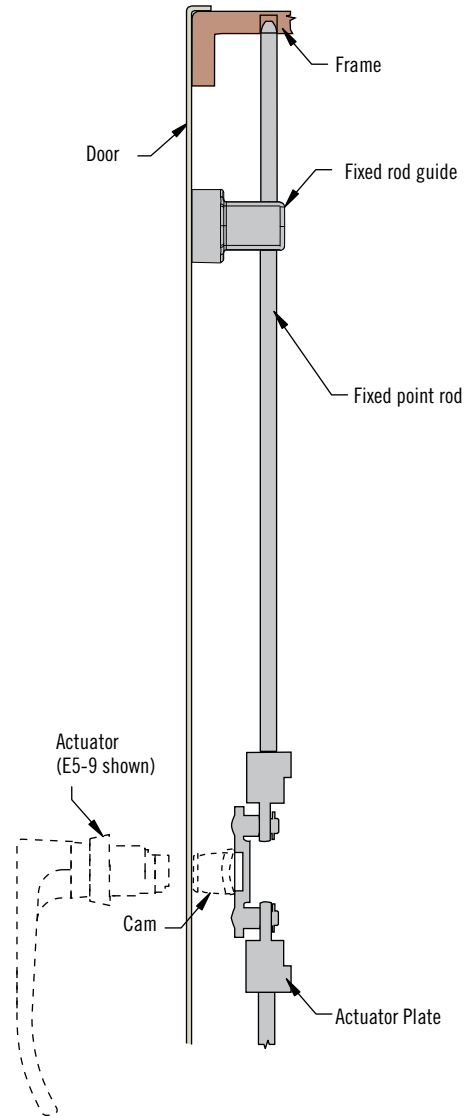

Notes

Modular system allows for any configuration of rod and rod guides



Southco® Multi-point Latching Systems

Fixed-rod Latching System

- For 2- and 3-point latching
- Assemblies include rods and guides
- Operates with multiple Southco® latch families

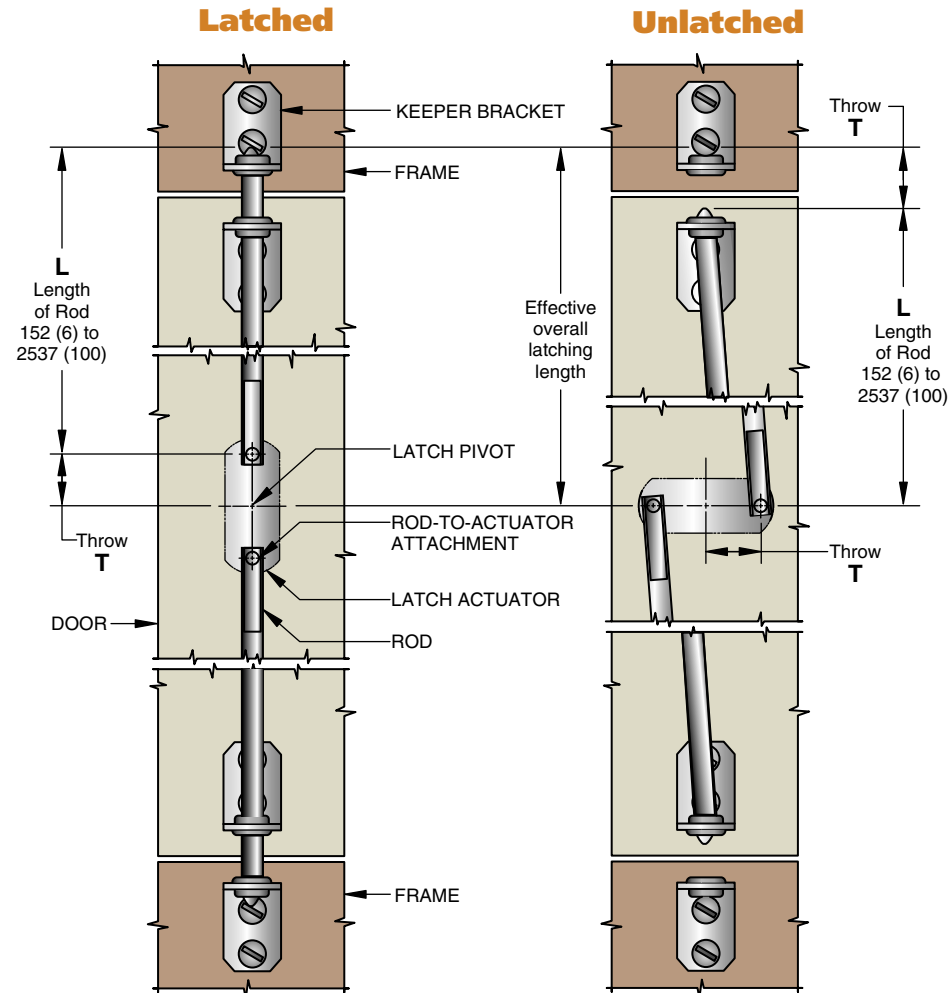

Guide and keeper bracket detail

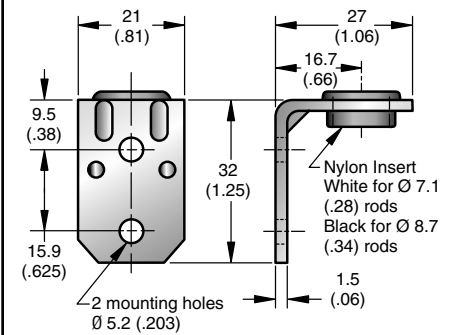

Rod detail

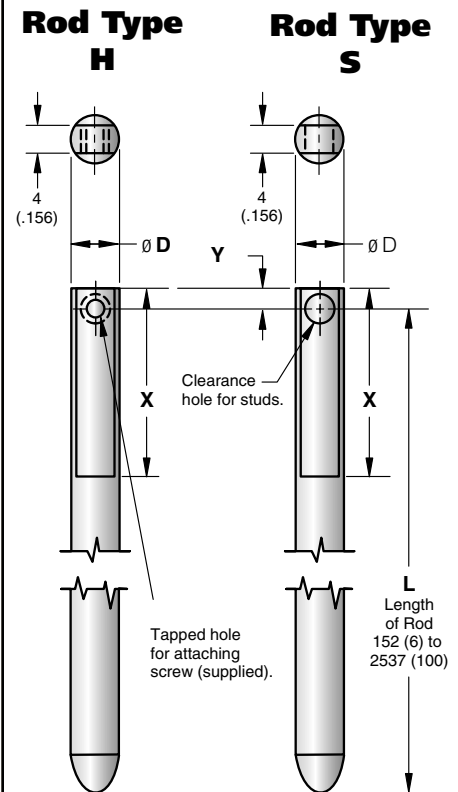

BASIC PART NUMBER	ROD ASSEMBLY TYPE	Ø D	HOLE SIZE	X	Y
A5-21-XXX-10	S	7.1 (.28)	Ø 4.2 (.166) clear.	30 (1.19)	3.2 (.13)
A5-22-XXX-10	H		Tapped No. 8-32		
A5-31-XXX-10	S	8.7 (.34)	Ø 5 (.196) clear.	44.5 (1.75)	4.7 (.19)
A5-32-XXX-10	H		Tapped No. 8-32		

STANDARD ROD LENGTHS

PART NUMBER XXX	L
120	305 (12.0)
240	610 (24.0)
360	914 (36.0)
480	1219 (48.0)

millimeter (inch)
millimeter
(inch)

Dimensions without tolerances are for reference only.

Multi-point Latching System

Southco® Multi-point Latching Systems

Fixed-rod Latching System

Rod Type S

To attach rod to latch actuators having integral studs and rod retainer.

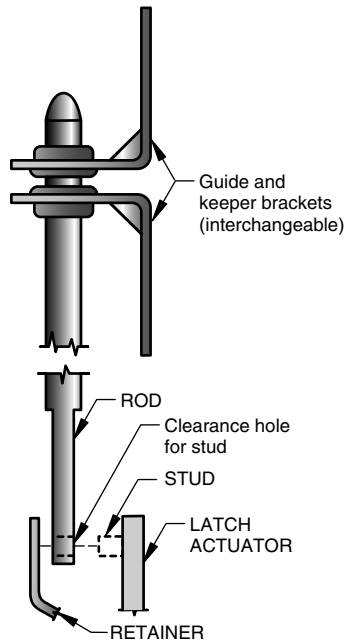

Rod Type H

To attach rod to latch actuators having Ø 6.4 (.250) holes.

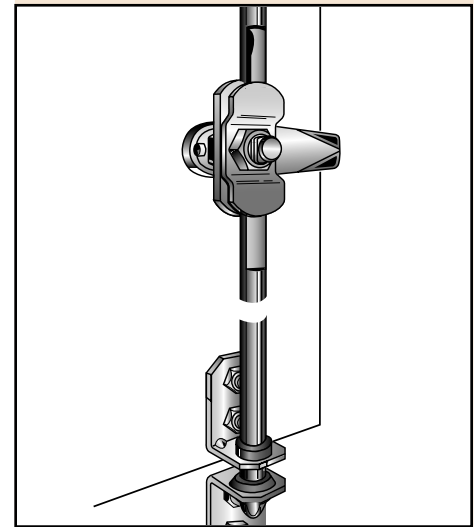
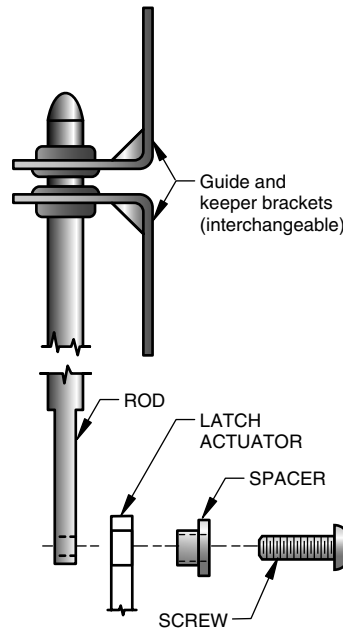

Material and Finish

RODS: Aluminum, natural.

BRACKETS: 1010 Steel, zinc plate, chromate plus sealer.





BRACKET INSERTS: Nylon, white or black.

FOR TYPE H ONLY, SPACERS: 12L14 Steel, zinc plate, chromate plus sealer.

SCREWS: Low carbon steel, zinc plated with bright chromate dip.

To order rod assemblies, (assembly consists of a guide, keeper and rod):

1. Determine basic part number from table below.

OPERATING LATCH FAMILIES	SIZE/STYLE	BASIC PART NUMBER	ROD TYPE	T
No. 01 Flush Cup Latches 	Small	A5-21-XXX-10	S	12.7 (.50)
	Mid-size	A5-31-XXX-10		19 (.75)
No. 24 Flush Cup Latches 	2 and 3 point assemblies (non-locking)	A5-32-XXX-10	H	17.5 (.69)
	Heavy Duty			31.8 (1.25)
	Large			22.2 (.88)
No. 62 Lift and Turn Latches 	Large (Flush)	A5-32-XXX-10	H	31.8 (1.25)
	Mid-size T-handle			17.5 (.69)
	Small T-handle			13.5 (.53)
	Large T-handle. Bail Handle (Series 80)			22.2 (.88)
No. 68 Bail and T-handle Latches 		A5-22-XXX-10		
No. 92 L-handle and T-handle Latches 		A5-32-XXX-10		
	ALL	A5-21-XXX-10	S	19 (.75)

2. Effective overall latching lengths = L length + T. L length rod 152 (6) to 2537 (99.9) MAX. must clear frame in unlatched position.

3. Select XXX part number based on length required. See Standard Rod Lengths Table for stocked lengths. Custom lengths are available contact Southco for details.

4. Order 1 latch with actuator option (as appropriate), 2 Rod Assemblies for a complete system. See appropriate page for latch part number.

Product Strength Guidelines

(To assist in your product selection; samples are available for your evaluation.)

Flammability Rating: UL94 - V2

millimeter (inch)
millimeter
(inch)

Dimensions without tolerances are for reference only.