



## 27 · 48 · Compression Latches

Self-adjusting · Single hole mount

- Two sizes available
- Easy grip adjustment
- Multiple head styles

### Material and Finish

Steel, zinc plated or stainless steel

### Performance Details

27 Working load: 155 N (35 lbf)

48 Working load: 220 N (50 lbf)

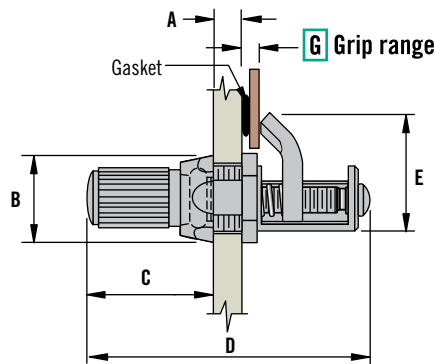

| Size                   | A                 | B                  | C                  | D              | E             |
|------------------------|-------------------|--------------------|--------------------|----------------|---------------|
| 27 Series<br>Miniature | 4.8 (.19)<br>Max. | 10.3 (.41)<br>Max. | 17.5 (.69)<br>Max. | 31.8<br>(1.25) | 13.9<br>(.55) |
| 48 Series<br>Small     | 4.8 (.19)<br>Max. | 21 (.81)<br>Max.   | 19 (.75)<br>Max.   | 44<br>(1.73)   | 25.3<br>(.99) |

Nylon knob

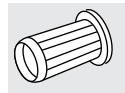

Knurled

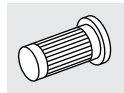

Slotted



Hex recess



Phillips recess

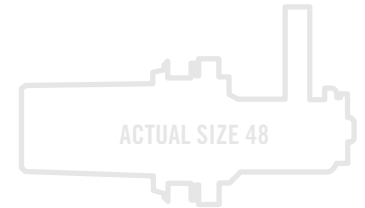

### 27 Series · Miniature

| Material        | G Grip Range |           | Knurled        | Slotted        | Hex Recess     | Nylon Knob     |
|-----------------|--------------|-----------|----------------|----------------|----------------|----------------|
|                 | Min.         | Max.      |                |                |                |                |
| Steel           | 0.8 (.03)    | 7.1 (.28) | 27-99-123-10 * | 27-10-501-10 * | 27-10-701-10 * | 27-10-311-10 * |
| Stainless steel | 0.8 (.03)    | 7.1 (.28) | 27-99-123-20 * | 27-10-501-20 * | 27-10-701-20 * | 27-10-311-20 * |

\* all part numbers shown are for clockwise rotation. For specification and ordering details visit: [www.southco.com/27](http://www.southco.com/27)

### 48 Series · Small

| Material | G Grip Range |            | Nylon Knob   | Slotted | Hex Recess | Phillips Recess |
|----------|--------------|------------|--------------|---------|------------|-----------------|
|          | Min.         | Max.       |              |         |            |                 |
| Steel    | 2.4 (.09)    | 9.5 (.38)  | 48-10-401-10 | 48-11-R | 48-81-R    | 48-91-R         |
| Steel    | 8.7 (.34)    | 15.9 (.63) | 48-10-402-10 | 48-12-R | 48-82-R    | 48-92-R         |
| Steel    | 15.1 (.59)   | 22.2 (.88) | 48-10-403-10 | 48-13-R | 48-83-R    | 48-93-R         |

For specification and ordering details visit: [www.southco.com/48](http://www.southco.com/48)

Other options available. For complete details on variety, part numbers, installation and specification, go to



[www.southco.com/27](http://www.southco.com/27)  
[www.southco.com/48](http://www.southco.com/48)

Dimensions in millimeters (inch) unless otherwise stated

**southco**  
CONNECT · CREATE · INNOVATE

# 16 Compression Latch

Self-adjusting · Cam indicator · Knob actuated · Single hole mount

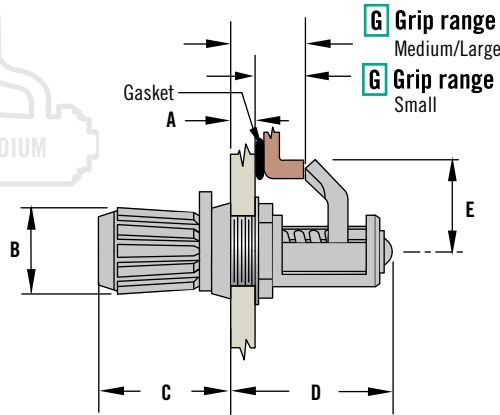
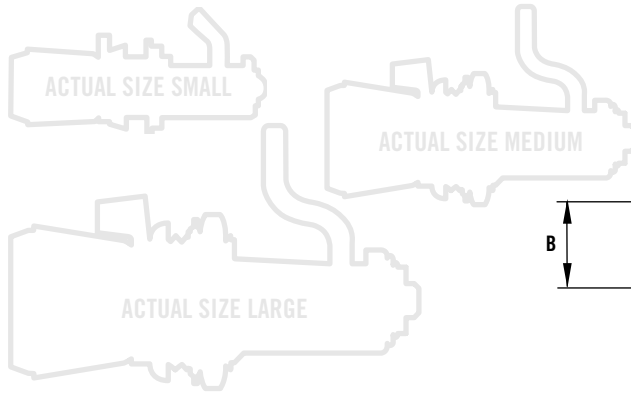

- Three sizes available
- Easy grip adjustment

### Material and Finish

Steel, zinc plated

### Performance Details

Small: Working load: 135 N (30 lbf)

Medium: Working load: 220 N (50 lbf)

Large: Working load: 335 N (75 lbf)

| Size   | G Grip Range |            | Part Number  |
|--------|--------------|------------|--------------|
|        | Min.         | Max.       |              |
| Small  | 3.2 (.12)    | 10.3 (.41) | 16-10-511-16 |
| Medium | 1.6 (.06)    | 8.7 (.34)  | 16-10-411-14 |
|        | 7.1 (.28)    | 14.3 (.56) | 16-10-412-14 |
| Large  | 1.6 (.06)    | 12.7 (.50) | 16-10-311-14 |
|        | 9.5 (.37)    | 20.6 (.81) | 16-10-312-14 |

| Size   | A. Max.    | B          | C          | D          | E        |
|--------|------------|------------|------------|------------|----------|
| Small  | 2.4 (.09)  | 9.9 (.39)  | 15.5 (.61) | 18.3 (.72) | 10 (.40) |
| Medium | 2.4 (.09)  | 13.5 (.53) | 17.3 (.68) | 23.4 (.92) | 19 (.75) |
| Large  | 4.8 (.190) | 19 (.75)   | 21.8 (.86) | 32.9 (1.3) | 23 (.91) |

Other options available. For complete details on variety, part numbers, installation and specification, go to



[www.southco.com/16](http://www.southco.com/16)

# 43 · 44 · 14 Compression Latches

Self-adjusting · Three hole mount



## 44 · Medium size series

| Material        | G Grip Range |             | Knurled Head | Slotted Head |
|-----------------|--------------|-------------|--------------|--------------|
|                 | Min.         | Max.        |              |              |
| Steel           | 3.2 (.12)    | 9.5 (.37)   | 44-1-1-0     | 44-1-16-0    |
|                 | 9.5 (.37)    | 19.1 (.75)  | 44-1-2-0     | 44-1-17-0    |
|                 | 19.1 (.75)   | 28.6 (1.12) | 44-1-3-0     | 44-1-18-0    |
| Stainless steel | 3.2 (.12)    | 9.5 (.37)   | 44-1-1-24    | 44-1-16-24   |
|                 | 9.5 (.37)    | 19.1 (.75)  | 44-1-2-24    | 44-1-17-24   |
|                 | 19.1 (.75)   | 28.6 (1.12) | 44-1-3-24    | 44-1-18-24   |

Also available: Tool recess, Slotted, Hex recess

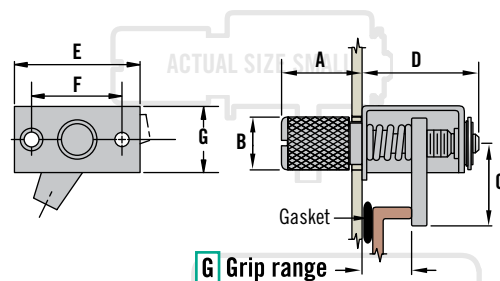

- Three sizes available
- Three hole installation
- Easy grip adjustment

### Material and Finish

Steel, zinc plated or stainless steel

### Performance Details

Working Load:

43 Small: 330 N (75 lbf)

44 Medium: 490 N (110 lbf)

14 Large: 670 N (150 lbf)

| Size      | A           | B          | C          | D           | E           | F           | G           |
|-----------|-------------|------------|------------|-------------|-------------|-------------|-------------|
| Small 43  | 15.1 (.59)  | 8.9 (.35)  | 15.9 (.63) | 22.2 (.88)  | 28.6 (1.13) | 20.6 (.81)  | 13.9 (.55)  |
| Medium 44 | 23.8 (.94)  | 14.6 (.57) | 25.4 (1.0) | 32.1 (1.27) | 44.5 (1.75) | 31.8 (1.25) | 22.2 (.88)  |
| Large 14  | 28.6 (1.13) | 22.7 (.90) | 34 (1.34)  | 44.5 (1.75) | 63.5 (2.5)  | 47.6 (1.87) | 33.3 (1.31) |

Other options available. For complete details on variety, part numbers, installation and specification, go to

[www.southco.com/43](http://www.southco.com/43)

[www.southco.com/44](http://www.southco.com/44)

[www.southco.com/14](http://www.southco.com/14)



# Southco® Compression Latches

## Miniature Size

- Single-hole installation
- An extra turn adjusts the amount of compression applied
- Corrosion-resistant assemblies available
- Four access styles including hand- and tool-operated

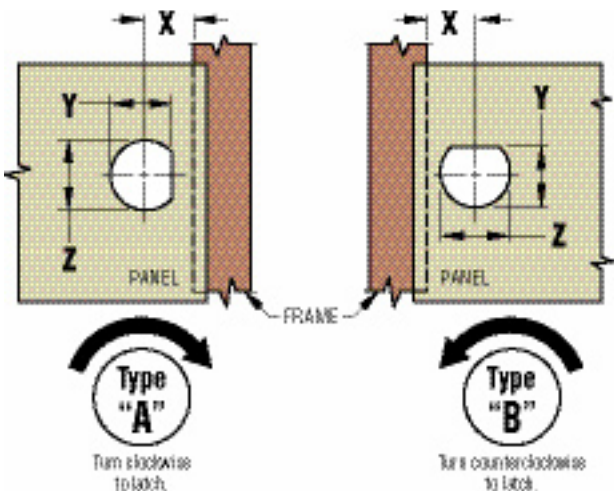
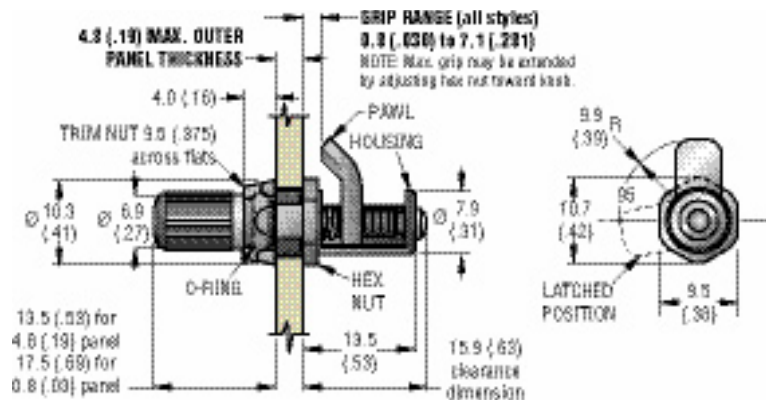

|          |                              |
|----------|------------------------------|
| <b>X</b> | 6.4 ± 0.7<br>(.250 ± .031)   |
| <b>Y</b> | 7.4 ± 0.1<br>(.292 ± .005)   |
| <b>Z</b> | 8.03 ± 0.05<br>(.316 ± .002) |

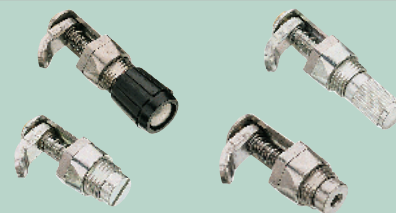

## Material and Finish

### For steel assemblies:

HOUSING and TRIM NUT: Low carbon steel, zinc plate, chromate plus sealer or chrome plated. PAWL: 1010 Steel, zinc plate, chromate plus sealer. SCREW: 12L14 Steel, zinc plate, chromate plus sealer or chrome plated. BUSHING: Brass, natural. SPRING: 302 Stainless steel, passivated. HEX NUT: 303 Stainless steel, passivated. O-RING: Buna-N rubber. KNOB: Nylon, black.

### For stainless steel assemblies:

HOUSING, SCREW and TRIM NUT: 303 Stainless steel, passivated or with black organic coating. BUSHING: Brass, natural. PAWL and SPRING: 302 Stainless steel, passivated. O-RING: Buna-N rubber. HEX NUT: 303 Stainless steel, passivated. KNOB: Nylon, black UL94-HB.

## Installation

1. Install latch from back side of panel.
2. Slip trim nut over knob, slotted head or hex socket head and finger tighten against panel.
3. With pawl in latched position, tighten hex nut hard against back of panel with 3/8" end wrench.

### For Black Nylon Knob style:

Be sure latch is properly attached and functioning then press knob onto knurled steel head of screw. Neither knob nor latch can be removed once knob is pressed into position.

## Product Strength Guidelines

(To assist in your product selection; samples are available for your evaluation.)

Maximum static load: 155 N (35 lbs.)

Average ultimate load: 400 N (90 lbs.)

Operating Temperature Range: -20°C (0°F) to 80°C (180°F)

Flammability Rating (KNOB): UL94-HB

## PART NUMBERS

| Material and Finish                        | Black Nylon Knob |                | Knurled Steel or Stainless Steel Knob |                | Low-profile Slotted Head |                | Hex-socket Head |
|--|------------------|----------------|---------------------------------------|----------------|--------------------------|----------------|-----------------|
|  | Type "A"         | Type "B"       | Type "A"                              | Type "B"       | Type "A"                 | Type "B"       | Type "A"        |
| Steel, zinc plated                         | 27-10-311-10 •   | 27-20-311-10 • | 27-99-123-10 •                        | 27-99-126-10 • | 27-10-501-10 •           | 27-20-501-10   | 27-10-701-10    |
| Stainless steel, passivated                | 27-10-311-20 •   | 27-20-311-20 • | 27-99-123-20 •                        | 27-99-126-20 • | 27-10-501-20 •           | 27-20-501-20 • | 27-10-701-20 •  |
| Steel, chrome plated                       | 27-10-311-30 •   | —              | 27-99-123-30 •                        | —              | 27-10-501-30             | —              | —               |
| Stainless steel with black organic coating | —                | —              | 27-99-123-50 •                        | 27-99-126-50 • | 27-10-501-50 •           | 27-20-501-50   | —               |

millimeter (inch)  
millimeter  
(inch)

Dimensions without tolerances are for reference only.

# Southco® Compression Latches

## Small Size

- Single-hole installation
- An extra turn adjusts the amount of compression applied
- Four access styles including hand- and tool-operated

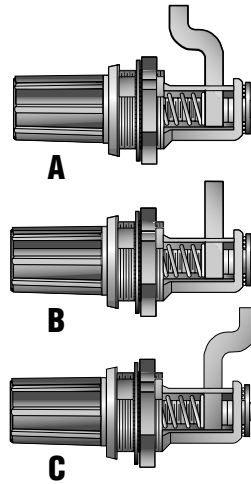
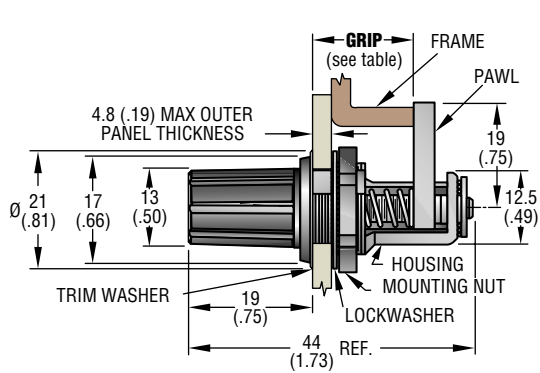

### Material and Finish

SCREW: Low carbon steel.  
 HEX NUT: 12L14 Steel.  
 TRIM WASHER: Steel.  
 LOCKWASHER: Steel.  
 PAWL: 1010 Steel.  
 BUSHING: 12L14 Steel. The above components are zinc plate chromate plus sealer.  
 SPRING and SPRING WASHER: 17-7PH Stainless steel.  
 KNOB: Nylon, black.  
 HOUSING: Die-cast zinc, chemical protective film.

### Installation

1. Prepare panel.
2. Rotate knob to run pawl to back of housing.
3. Remove mounting nut and lockwasher.
4. Insert latch into hole by hooking pawl through hole.
5. Replace lockwasher and mounting nut; tighten with wrench.

### Product Strength Guidelines

(To assist in your product selection; samples are available for your evaluation.)  
 Maximum static load: 220 N (50 lbs.)  
 Average ultimate load: 445 N (100 lbs.)  
**Operating Temperature Range:** -20°C (0°F) to 80°C (180°F)  
**Flammability Rating (KNOB):** UL94 - V2

## Panel preparation

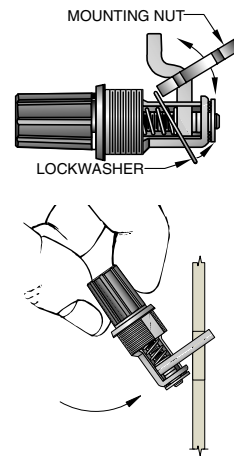
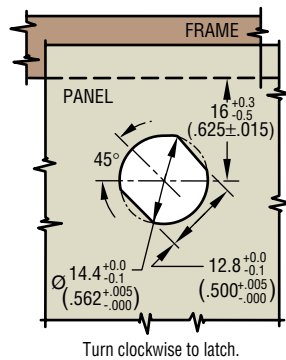

| GRIP RANGE |            | PART NUMBERS   |   |   |   | Pawl Position |
|------------|------------|----------------|---|---|---|---------------|
|            |            | Knob Style     | Slotted Head  | Hex Socket                                      | Phillips Recess                             |               |
| MIN.       | MAX.       |                | slot width = 1.3 (.050)<br>slot depth = 2 (.078)<br>Ø13 (.50)<br> | Hex Socket size is 4 mm (5/32)<br>Ø13 (.50)<br> | No. 2 size phillips recess<br>Ø13 (.50)<br> |               |
| 2.4 (.09)  | 9.5 (.38)  | 48-10-401-10 • | 48-11-R •   | 48-81-R •                                       | 48-91-R •                                   | <b>A</b>      |
| 8.7 (.34)  | 15.9 (.63) | 48-10-402-10 • | 48-12-R •   | 48-82-R •                                       | 48-92-R •                                   | <b>B</b>      |
| 15.1 (.59) | 22.2 (.88) | 48-10-403-10 • | 48-13-R •   | 48-83-R •                                       | 48-93-R •                                   | <b>C</b>      |

millimeter (inch)  
 millimeter (inch)

Dimensions without tolerances are for reference only.

# Southco® Compression Latches

## Pawl Indicator Style

- Arrow indicates pawl position
- Single-hole installation
- An extra turn adjusts the amount of compression applied
- Three sizes

**500 series**  
**PART NUMBER**  
**16-10-511-16 •**

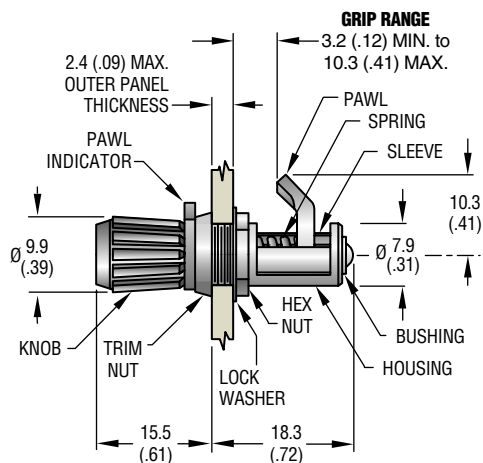

## 300 and 400 series (see table below for PART NUMBERS)

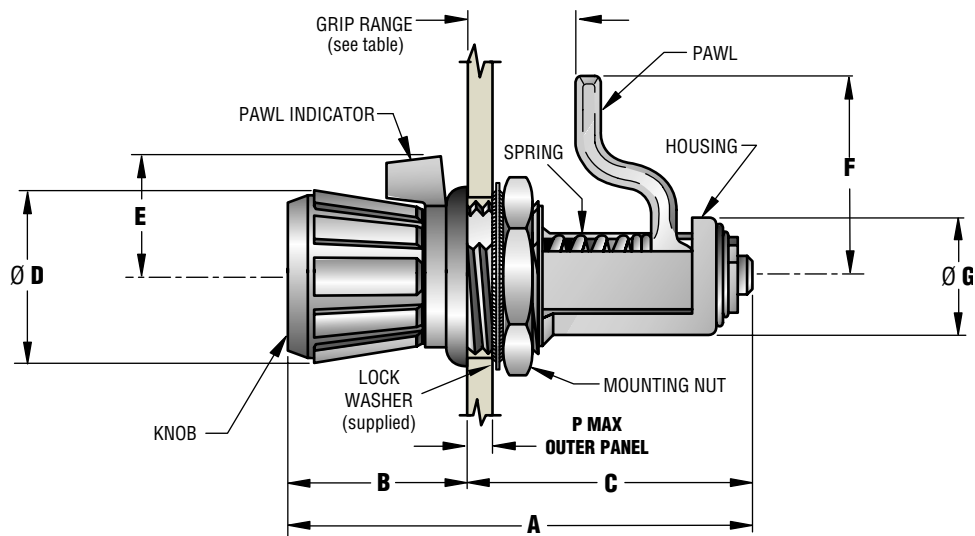

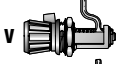
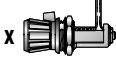
| DIMENSIONS     |               |                |               |               |             |               |              | GRIP       |             | PART NUMBERS   | Pawl position | Series | INSTALLATION   |                |               |                |                | Pawl style and position (pre-assembled)  |
|----------------|---------------|----------------|---------------|---------------|-------------|---------------|--------------|------------|-------------|----------------|---------------|--------|----------------|----------------|---------------|----------------|----------------|--|
| A              | B             | C              | D             | E             | F           | G             | P            | MIN.       | MAX.        |                |               |        | H              | K              | M             | N              |                |  |
|                |               |                |               |               |             |               |              |            |             |                |               |        | MIN.           | MAX.           |               |                |                |  |
| 54.8<br>(2.16) | 21.8<br>(.86) | 32.9<br>(1.30) | 19<br>(.75)   | 12.7<br>(.50) | 23<br>(.91) | 15.5<br>(.61) | 4.8<br>(.19) | 1.6 (.063) | 12.7 (.500) | 16-10-311-14 • | V             | 300    | 19<br>(.750)   | 17.5<br>(.687) | 8.7<br>(.344) | 17.5<br>(.688) | 20.6<br>(.813) | <br> |
|                |               |                |               |               |             |               |              | 9.5 (.375) | 20.6 (.813) | 16-10-312-14 • | X             |        |                |                |               |                |                |  |
| 40.7<br>(1.60) | 17.3<br>(.68) | 23.4<br>(.92)  | 13.5<br>(.53) | 9.1<br>(.36)  | 19<br>(.75) | 11.5<br>(.45) | 2.4<br>(.09) | 1.6 (.063) | 8.7 (.344)  | 16-10-411-14 • | V             | 400    | 14.3<br>(.562) | 12.7<br>(.500) | 6.4<br>(.250) | 14.3<br>(.563) | 17.5<br>(.688) |  |
|                |               |                |               |               |             |               |              | 7.1 (.28)  | 14.3 (.563) | 16-10-412-14 • | X             |        |                |                |               |                |                |  |



## Installation (500 series)

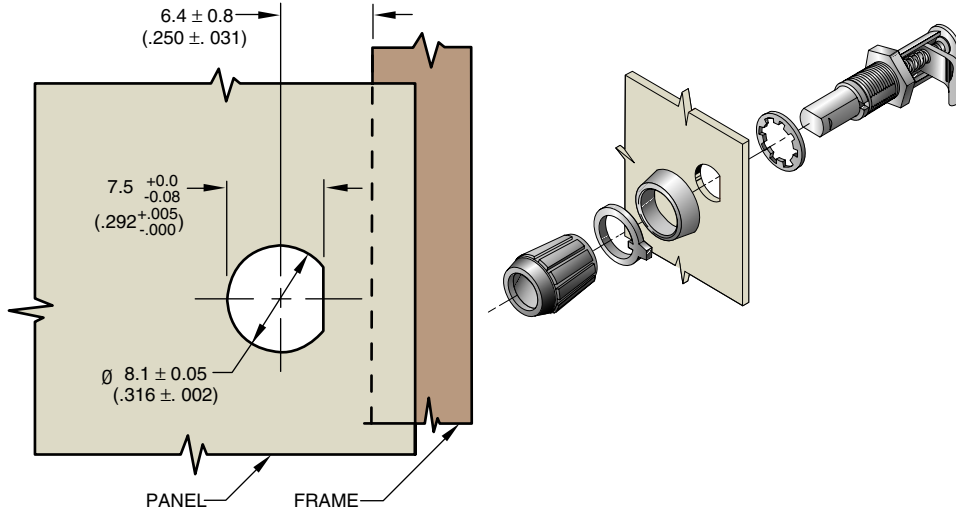

## Material and Finish

### (500 series)

SCREW and SLEEVE: 12L14 Steel. HOUSING: Low carbon steel. PAWL: 1010 Steel. LOCKWASHER: Spring steel. All components listed above are zinc plate, chromate plus sealer. BUSHING: 12L14 Steel, zinc plate chromate plus sealer or brass, natural. TRIM NUT and HEX NUT: 303 Stainless steel, passivated. COIL SPRING and PAWL INDICATOR: 302 Stainless steel, passivated. KNOB: Nylon, black.

### (300 and 400 series)

BUSHING: Low carbon steel. RETAINING WASHER: 1010 Steel. The components listed above are zinc plate, chromate plus sealer. LOCKWASHER: Spring steel, zinc immersion coating. SCREW: Low carbon steel with black organic coating. SPRING and CONICAL SPRING: 302 Stainless steel, passivated. PAWL: Die-cast zinc with chemical protective coating. MOUNTING NUT: 12L14 Steel, zinc plate, chromate plus sealer. KNOB: Nylon, black. HOUSING and PAWL INDICATOR: Die-cast zinc, chrome plated.  
**400 series:** LOCKWASHER: Spring steel, zinc plate chromate plus sealer.

## Installation (300 and 400 series)

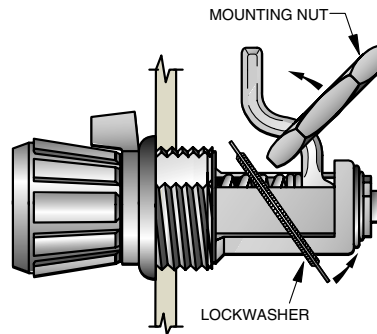
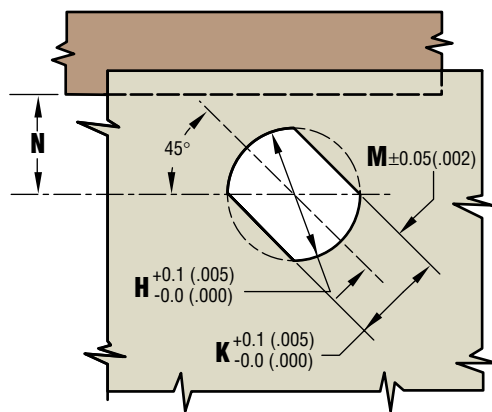

## Installation

### (500 series)

1. Prepare panel.
2. Remove trim nut from latch assembly and install latch from back side of panel.
3. Tighten hex nut.
4. Align tang on inside diameter of indicator with slot in head of sleeve, slide into position and press knob over head of screw. **NOTE:** Neither knob nor latch can be removed once knob is pressed into position.

### (300 and 400 series)

1. Prepare panel.
2. Rotate knob to run pawl to back of housing.
3. Remove mounting nut and lockwasher.
4. Insert latch into hole by hooking pawl through hole, following through with housing.
5. Replace lockwasher and mounting nut and tighten.

## PRODUCT STRENGTH GUIDELINES

(To assist in your product selection; samples are available for your evaluation.)

| Series | MAX. static load | Average ultimate load |
|--------|------------------|-----------------------|
| 300    | 335 N (75 lbs.)  | 445 N (100 lbs.)      |
| 400    | 220 N (50 lbs.)  | 330 N (75 lbs.)       |
| 500    | 135 N (30 lbs.)  | 200 N (45 lbs.)       |

Flammability Rating (Nylon knob): UL94 - HB

Operating Temperature Range (Nylon knob):  
-20°C (0°F) to 80°C (180°F)

millimeter (inch)  
millimeter  
(inch)

Dimensions without tolerances are for reference only.

16-0-2345-16  
16-0-34417-16  
16-10-311-14  
16-10-312-14  
16-10-313-14  
16-10-411-14  
16-10-412-14  
16-10-413-14  
16-10-511-16  
16-23-101-41  
16-23-201-41  
16-23-401-41  
27-10-311-10  
27-10-311-20  
27-10-501-10  
27-10-501-20  
27-10-501-50  
27-10-701-10  
27-10-701-20  
27-20-311-10  
27-20-311-20  
27-20-501-10  
27-20-501-20  
27-20-501-50  
27-71-101-41  
27-83-301-24  
27-99-123-10  
27-99-123-20  
27-99-123-30  
27-99-123-50  
27-99-126-10  
27-99-126-20  
27-99-126-50  
48-10-401-10  
48-10-402-10  
48-10-403-10  
48-11-R  
48-12-L  
48-12-R  
48-13-R  
48-20-401-10  
48-20-403-10  
48-81-R  
48-82-R  
48-83-R  
48-91-R  
48-92-L  
48-92-R  
48-93-R