



24 Cam Latch

Flush T-handle · Adjustable grip

- **Concealed mounting type**

Material and Finish

Zinc and steel, zinc plated or stainless steel

Performance Details

Max. static load: 445 N (100 lbf)

Installation Notes

Max. tightening torque of mounting nuts not to exceed 2.8 N·m (25 in·lbf)

Keys

See page 98

Other options available. For complete details on variety, part numbers, installation and specification, go to



www.southco.com/24

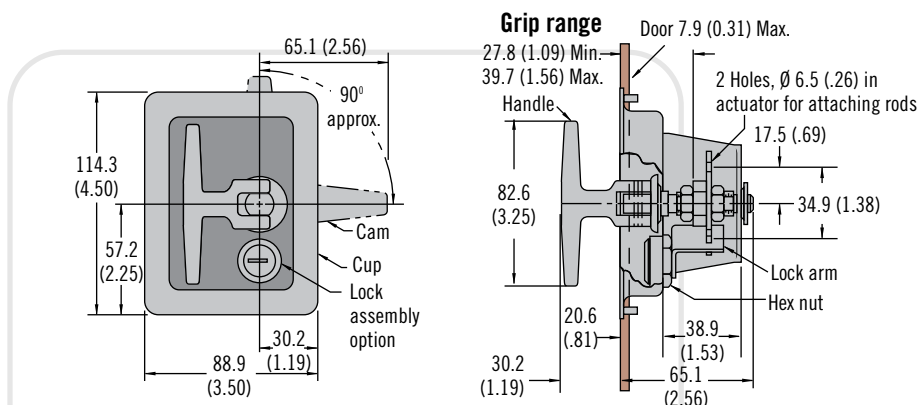

Part Number

Style	With Mounting Studs	
	Cup and bracket polished stainless steel. Handle zinc chrome plated	Cup and bracket steel dacrotized. Handle zinc dacrotized
	Type A	Type A
Locking keyed alike CH751 supplied	24-20-812-35	24-20-812-10
Non-locking	24-20-302-35	24-20-302-10
Non-locking environmentally sealed	24-20-312-35	24-20-312-10



69 Cam Latch

Arrowhead · Detent design · Adjustable grip

- **Single hole install**
- **Detented design**
- **Adjustable grip**

Material and Finish

Nylon and steel, zinc plated

Performance Details

Small working load: 44 N (10 lbf)

Medium working load:
220 N (50 lbf)

Large working load 330 N: (75 lbf)

Other options available. For complete details on variety, part numbers, installation and specification, go to



www.southco.com/69

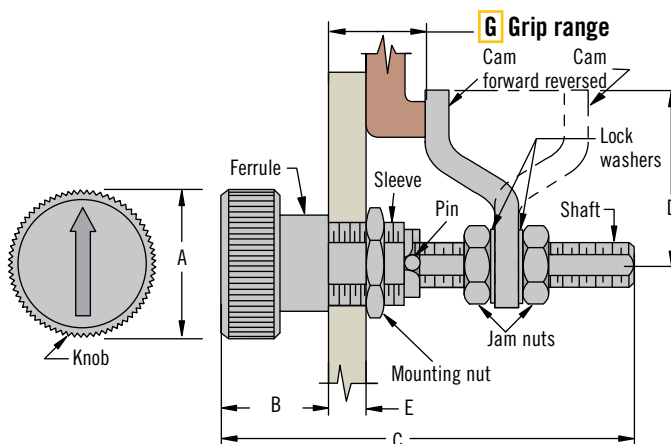

Size	Part Number	G Grip range		A	B	C	D	E
		Min.	Max.					
Small	69-10-301-11	4 (.16)	28.2 (1.11)	12.7 (.50)	12.7 (.50) Max.	38.1 (1.50)	13.5 (.53)	4.75 (.188)
Medium	69-10-401-11	3.2 (.13)	33.3 (1.31)	19.1 (.75)	17.5 (.69) Max.	47.5 (1.87)	15.9 (.63)	6.35 (.25)
Large	69-10-501-11	4.8 (.19)	61.9 (2.44)	28.6 (1.13)	25.4 (1) Max.	79.2 (3.12)	34.1 (1.34)	12.7 (.50)

Dimensions in millimeters (inch) unless otherwise stated

Southco® Pawl/Cam Action Latches

Arrowhead (Pawl Indicator) Design

- Detents in full open and closed positions
- Turn clockwise or counter-clockwise to operate

Height of knob (from outside surface of panel) is adjustable within limits shown by adjusting ferrule on threaded sleeve before installing latch. MAX. OUTER PANEL THICKNESS and GRIP RANGE are governed by specific knob height selected – (see table).

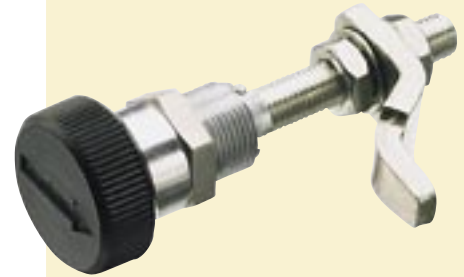
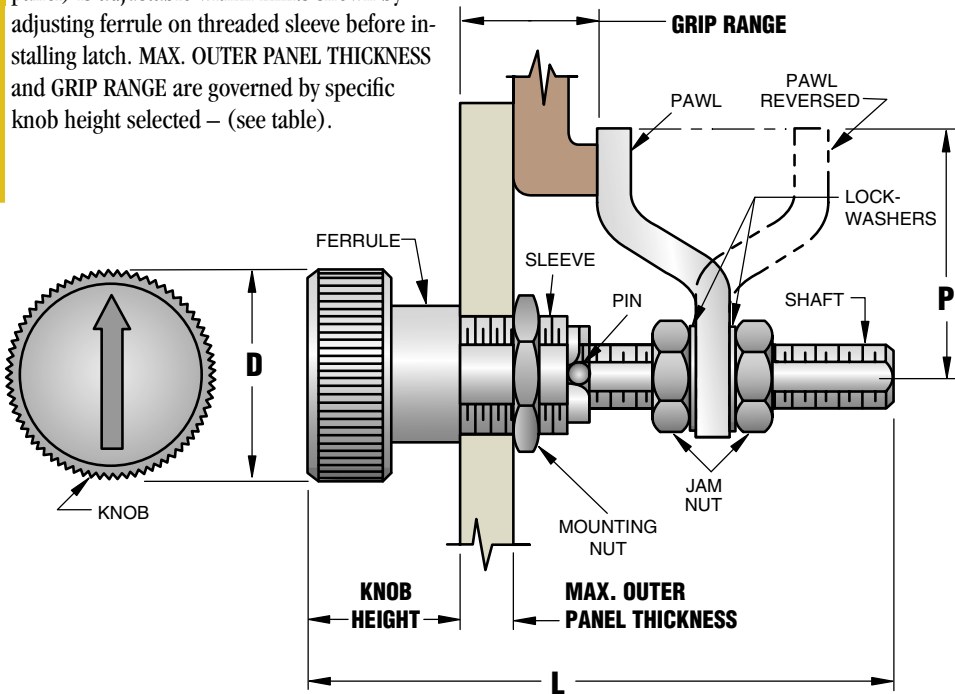

Material and Finish

KNOB: Nylon, black. **SHAFT:** Low carbon steel, zinc plate, chromate plus sealer. **PAWL:** 1010 Steel, zinc plate, chromate plus sealer. **FERRULE:** 6061 Aluminum, natural. **SLEEVE:** Die-cast zinc with chemical protective film. **MOUNTING NUT: (300 SERIES)** 303 Stainless steel, passivated. **MOUNTING NUT: (Other series)** Steel, zinc plated plus chromate dip. **JAM NUTS:** Steel, zinc plate, chromate plus sealer. **SPRING:** 302 Stainless steel, natural. **PIN:** 303 Stainless steel, natural. **WASHER:** Stainless steel, passivated. **LOCKWASHERS:** (300 Series) Stainless steel, passivated. **LOCKWASHERS: (Other Series)** Spring steel, zinc immersion coating.

DIMENSIONS			KNOB HEIGHT	Max. Outer Panel Thickness	GRIP RANGE				PART NUMBERS	Series	INSTALLATION				shaft thread size
ØD	L	P			Pawl as shown		Pawl reversed				X				
					MIN.	MAX.	MIN.	MAX.			MIN.	MAX.			
12.7 (0.50)	38.1 (1.50)	13.5 (0.53)	12.7 (.50) MAX.	1.59 (.063)	4 (.16)	13.4 (.53)	15 (.59)	24.6 (.97)	69-10-301-11 •	300	8.33 (.328)	6.99 (.275)	9.53 (.375)	11.11 (.438)	6-32 UNC
			9.5 (.38) MIN.	4.75 (.188)	7.1 (.28)	18.3 (.72)	18.3 (.72)	28.2 (1.11)							
19.1 (0.75)	47.5 (1.87)	15.9 (.63)	17.5 (.69) MAX.	1.59 (.063)	3.2 (.13)	15.9 (.63)	15.9 (.63)	28.6 (1.13)	69-10-401-11 •	400	11.51 (.453)	9.78 (.385)	12.30 (.484)	13.10 (.516)	10-32 UNF
			12.7 (.50) MIN.	6.35 (.250)	7.9 (.31)	20.6 (.81)	20.6 (.81)	33.3 (1.31)							
28.6 (1.13)	79.2 (3.12)	34.1 (1.34)	25.4 (1.00) MAX.	6.35 (.250)	4.8 (.19)	30.2 (1.19)	30.2 (1.19)	55.6 (2.19)	69-10-501-11 •	500	16.26 (.640)	13.72 (.540)	22.23 (.875)	25.40 (1.000)	5/16-24 UNF
			19.1 (.75) MIN.	12.70 (.500)	11.1 (.44)	36.5 (1.44)	36.5 (1.44)	61.9 (2.44)							

Panel Preparation

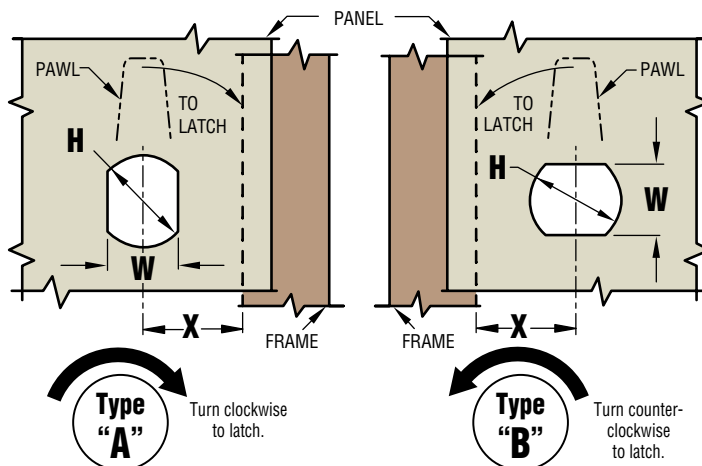

Installation

Latch operates through 90° rotation in direction shown with a positive click stop at both extremes. Pawl pulls up at both extremes.

1. Adjust ferrule to desired knob height (see table).
2. Remove shaft nuts, lockwashers, pawl and mounting nut (if assembled).
3. Insert shaft through hole in panel to engage flats of sleeve with shaped hole.
4. Check arrow orientation.
5. Apply and tighten mounting nut.
6. Install pawl and shaft nuts as shown, position pawl for desired grip and use two wrenches to tighten nuts firmly against pawl.

millimeter (inch)
millimeter
(inch)

Dimensions without tolerances are for reference only.