



ENGINEERED ACCESS SOLUTIONS FOR
INDUSTRIAL APPLICATIONS



Products

Compression & Cam Latches



Hinges & Display Mounts



Draw Latches



Quick Access & Captive Screws



Rotary Latches & Actuators



Push-to-Close Latches



Your solutions provider

At Southco, we believe in empowering our customers to connect, create and innovate – solving design challenges through dedicated engineering customization capability and a standard catalogue of 45,000 industry proven products. We understand that choosing the right components is crucial to your product's success.

Do you need to...

... enhance your competitive design advantage?

... increase assembly efficiencies?

... maximize safety and performance?

We can help solve your design challenges!

Compliance

Southco provides products tested to industry standards to speed your design through testing and compliance:

- Safety: Machinery Directive 2006/42/EC
- Fire Resistance: EN45545-3
- Dust & Moisture Ingress: IP65/NEMA 4 and IP69K



Security



Stainless Steel



Vibration Resistance



Fire Resistance



Design Differentiation

More intuitive and stylized equipment adds value and competitive advantage. Position Control Hinges and Display Mounting Solutions designed with integrated constant torque provide smooth operation, improving user ergonomics.

- Defined hinge torque dialed into exact end user needs
- Grab and move positioning prevents screen drift and movement
- Streamlined design with covered hinge points
- Standard and custom finishes and colour to complement industrial design

Office & Factory Equipment

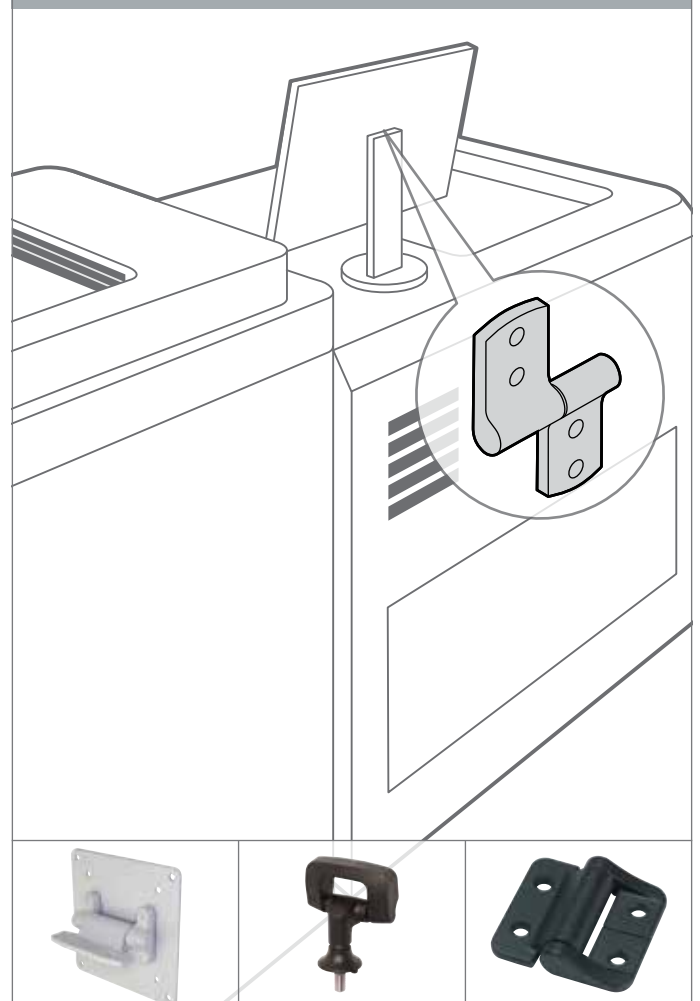

Hinges & Display Mounts



Safety & Security

Failure to comply with safety regulations can make or break an application. *DZUS*® Quarter-Turn Fasteners provide quick access and are available in a captive option that secures side panels on manufacturing machinery and equipment for improved safety during operation.

- Secure captive receptacles that prevent lost or dropped hardware
- Vibration resistant hardware ensures safe equipment operation
- Snap-in and clip-on receptacles speed assembly time and reduce costs

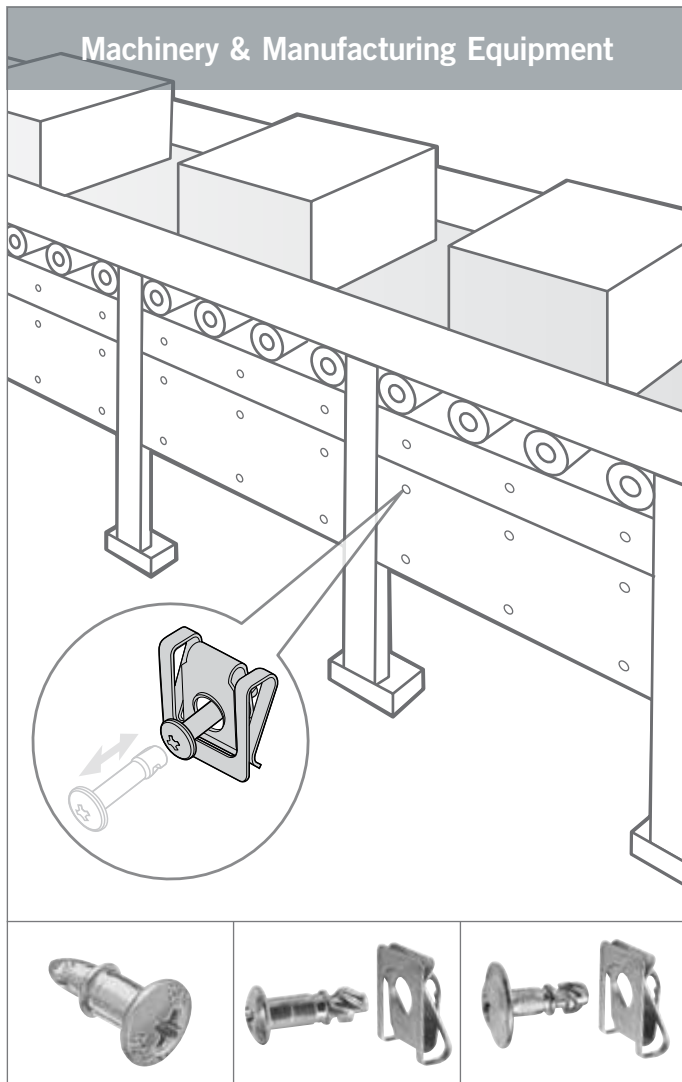

Quick Access & Captive Fasteners

Efficiency & Consistency

Hardware designed with fewer components streamlines assembly and production processes. Fixed grip, pre-set latches like Southco's *VISE ACTION*® Compression Latch series seals panels while restricting contamination and noise, and offers savings in production line and installation costs.

- Fixed grip option eliminates user adjustment
- Fewer parts to install increases assembly efficiency
- Repeatable compression enables production and operation consistency
- Single-hole mounting styles provide convenient installation

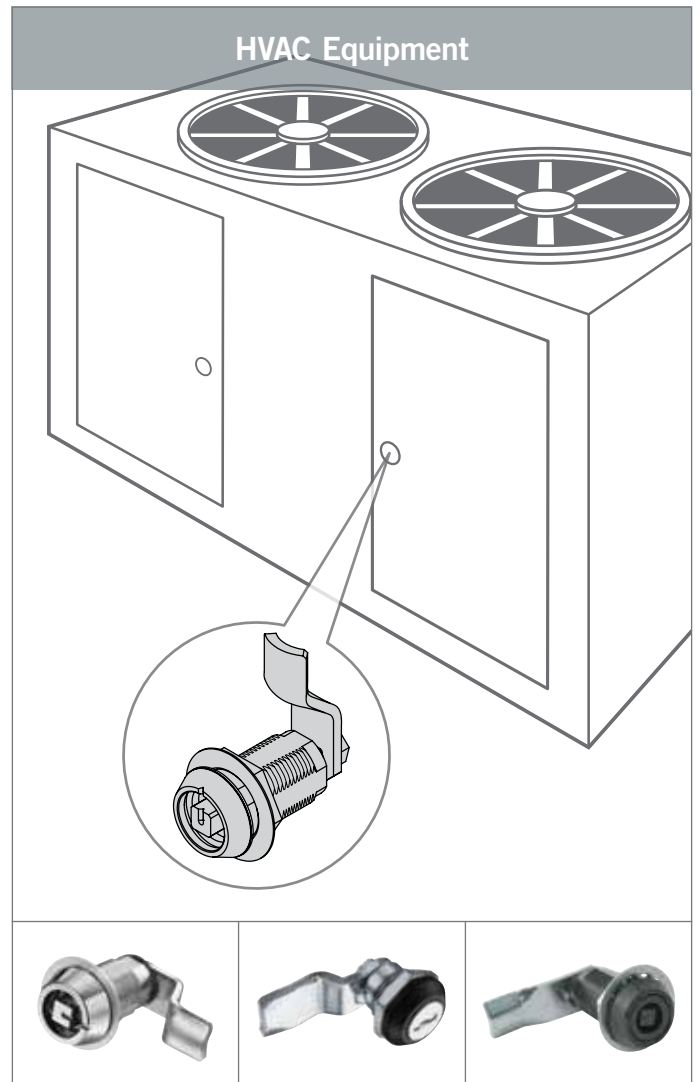

Compression & Cam Latches



Performance

Durable components offer increased equipment longevity, whether used indoors or out. Southco's line of miniature stainless steel Draw Latches securely seal covers and panels, ensuring optimal equipment performance regardless of weather and temperature variations.

- Stainless steel for corrosion resistance to outdoor elements
- External mount eliminates interference with internal machinery
- Draw spring provides vibration resistance and noise reduction

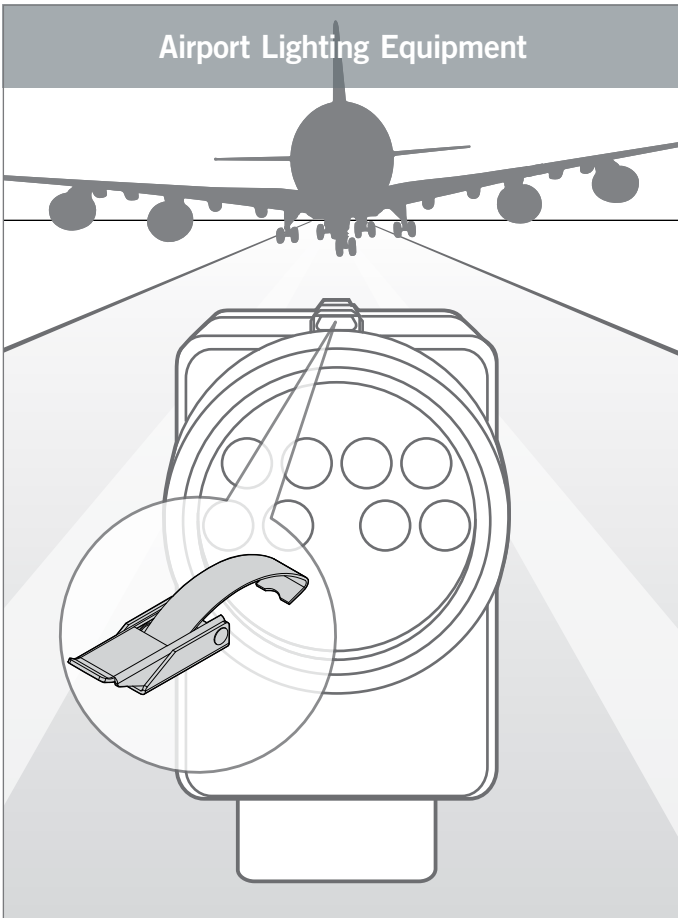

Draw Latches

Flexibility

Unique design challenges demand flexible solutions. Southco's R4 Rotary Latch series secures doors and panels and is available with differing performance attributes and mounting options to meet the unique needs of the application.

- Concealed latch and actuation options improve industrial design
- Slam to close function allows safe, user friendly operation
- Single or Dual Point latching secures small and large doors
- Remote actuation allows flexibility of actuation point

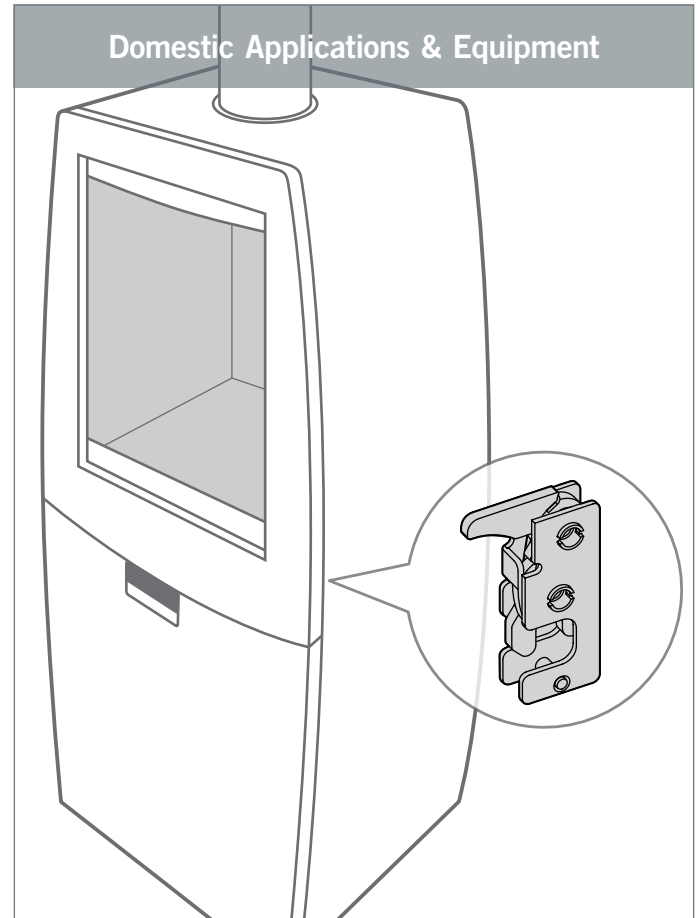

Mechanical & Electronic Rotary Latches

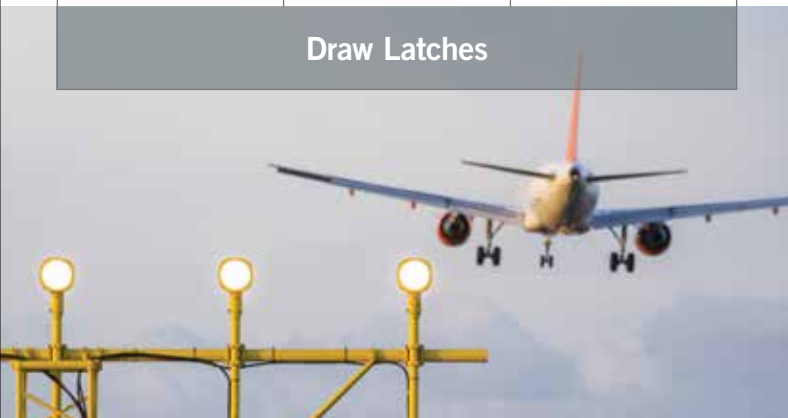

Your global access solutions provider



For over 100 years, Southco has helped customers solve and overcome engineering challenges and our passion, vision and focus today is to help customers differentiate their products' engineered touch points.

Southco is a leading global supplier with real global reach. Having more than 3000 employees in over 20 countries, together with sales, distribution, engineering and customer service centres in over 30 countries and 14 manufacturing sites - Southco can support you wherever you are in the world.

Americas Global Headquarters
Concordville, PA · USA
Tel: (1) 610 459 4000

Brazil Tel: (55 11) 4617 9988
 Canada Tel: (1) 905 855 0309
 Mexico Tel: (1) 877 821 0666
 USA Tel: (1) 610 459 4000

Europe Headquarters
Worcester · UK
Tel: (44) (0) 1905 346722

Austria Tel: 0800 281 831
 France Tel: 0800 912 756
 Germany Tel: 0800 1800 380
 Italy Tel: 800 780 953
 Spain Tel: 900 968917
 Sweden Tel: 020 790 366
 UK & NI Tel: 0845 117 922

Asia Headquarters
Hong Kong · China
Tel: (852) 3127 1503

Australia Tel: (61) 03 9330 5000
 China Tel: (800) 820 0272
 Tel: (400) 880 8900
 India Tel: (91) (21) 3867 0538
 Japan Tel: (81) 6 6466 1200
 Korea Tel: 0505 777 1234
 Malaysia Tel: 1800 801 119
 Singapore Tel: 800 18 11016
 Taiwan Tel: 0800 558 015

Visit www.southco.com for all your Access Hardware needs

-  Download CAD Files
-  Request Samples
-  Check Stock
-  Order Print Catalog
-  Access Online Catalog
-  User Account
-  Compliance Statements
-  Online Chat

 **Fast Answers 24/7**
info@southco.com

WORLDWIDE MANUFACTURING AND STOCKING LOCATIONS

Concordville, Pennsylvania, USA · Honeoye Falls, New York, USA · Philadelphia, Pennsylvania, USA · Chihuahua, Mexico · Tecate, Mexico · São Paulo, Brazil
 Farnham, UK · Worcester, UK · Hong Kong, China · Shenzhen, China · Shanghai, China · Seoul, Korea · Melbourne, Australia · Pune, India · Osaka, Japan