



**Ergonomics -**

Precise positioning of  
healthcare equipment

# Proven supplier of healthcare solutions

Southco healthcare access hardware solutions combine physical product strength with ease of installation and user-friendly operation. These products and systems provide greater flexibility, reliability and lower overall cost of ownership than hardware available from other manufacturers. As a system specialist, we offer a complete range of products that meet the healthcare industry standards for security, safety, precision and hygiene.



■ POSITION IT

■ CONCEAL IT

■ MOUNT IT

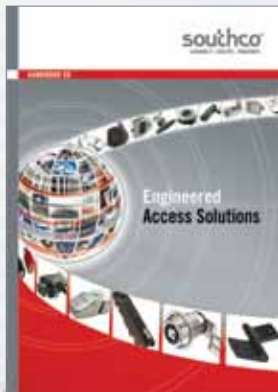

Order your **FREE Southco Handbook** on [info@southco.com](mailto:info@southco.com) and gain access to the industry's most comprehensive resource for access hardware solutions.



■ CONTROL IT

■ ACCESS IT

■ FASTEN IT

■ SECURE IT

■ OPEN IT

Please visit [www.southco.com](http://www.southco.com) to view our complete range of solutions

## Southco Positioning Technology

*- the healthcare industry's choice for user-friendly motion*

The positioning ease of monitors and medical devices is essential to optimal user comfort and patient care. As a long-time partner of top global healthcare equipment manufacturers, Southco leads the way in positioning technology within the healthcare sector.

- Ensuring user interfaces are within easy reach
- Allowing precisely positioned lighting
- Enabling equipment to be firmly held and easily repositioned, without mechanical lock
- Permitting heavy covers and lids to be lifted with minimal effort
- Providing reliability without maintenance or adjustment

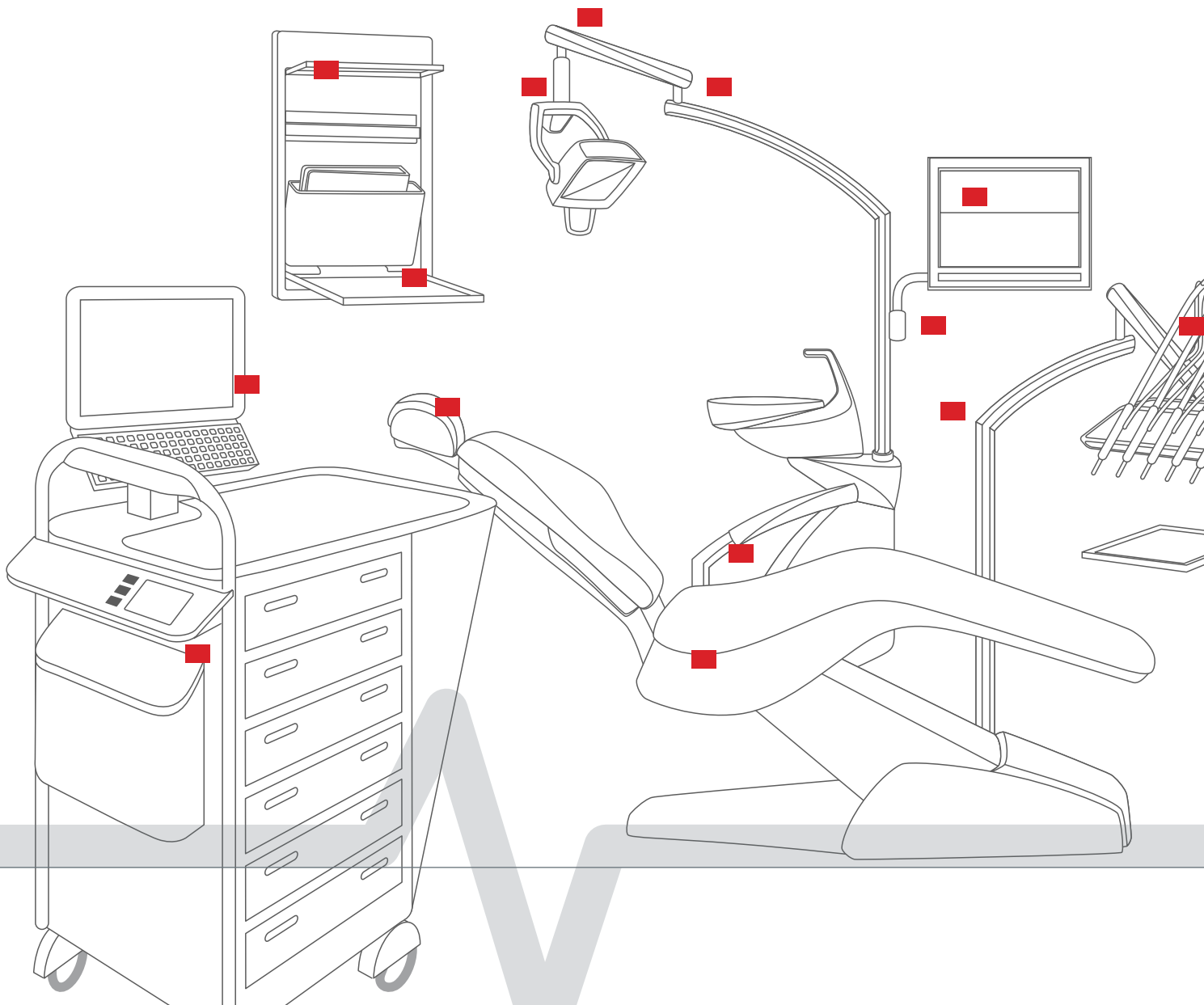

## Position Control Hinges and Mounting Arms

- *controlled movement and positioning of equipment*

Southco's engineering expertise in positioning technology enhances functionality, precision and user experience of healthcare equipment. From the most basic friction hinges, to highly sophisticated position control devices, Southco's reliable solutions ensure long-lasting performance throughout the life of your product.

- Constant torque hinges for smooth and secure positioning of keyboards, screens, headrests and lighting
- Counterbalance mechanisms to lift heavy equipment effortlessly
- Bi-stable hinges for the controlled motion of flip lids on portable devices
- Tilt and swivel mechanisms for easy screen adjustment and shared screen views
- Arms for easy 'no drift' positioning of monitors

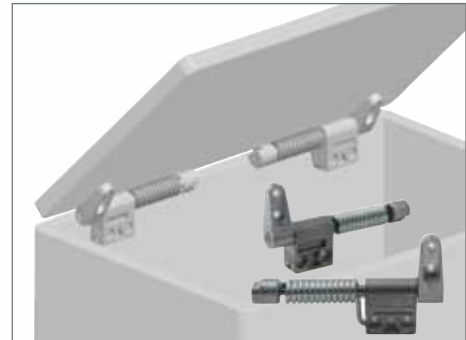
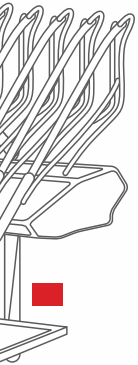
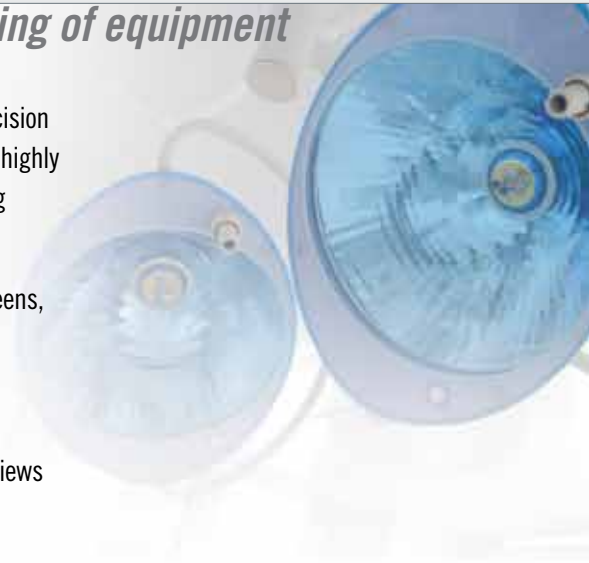



## Custom Designed Solutions - unparalleled flexibility

Southco's custom engineered position control solutions will give your medical equipment the competitive edge. From integrating a hinge into existing requirements to custom tailoring a complete solution, our global engineering team can satisfy the industrial design, operating effort, degree of motion and vibration resistance requirements with ease.

- Position hinges for portable computer displays to fit specific packaging and strength requirements
- Monitor arms that can be removed from the equipment and mounted elsewhere
- Position devices that permit screens to fold flat for transport yet hold securely against touch screen forces while in use
- Multi-axis monitor arms that allow for unlimited positioning options



## The proven global leader in engineered access solutions

The advantage of 60 years of engineered access hardware and fastener experience lies in our cumulative applications knowledge and engineering expertise that make our broad range of existing solutions possible. In addition, our global manufacturing resources benefit OEMs and CEMs worldwide - no matter where they design, assemble, or sell. Southco offers flexibility and fast response:

- **Engineering assistance on your schedule.** Southco engineering resources in three key regions - North America, Europe, and Asia-Pacific - provide easy access to more than 150 design and sales engineers globally.
- **Quick turnaround, on your timetable.** 14 strategically located Southco manufacturing, assembly, and stocking facilities - in 8 countries across 4 continents - shorten lead times, lower shipping costs, and improve scheduling.
- **Extensive capabilities for your benefit.** In-house resources - stamping, die-casting, cold-heading, roll-forming, turning, injection-molding, and assembly - at Southco Centres of Excellence around the world transform raw stock into polished solutions.
- **Personal assistance, as you need it.** The 24/7 availability of experienced Southco personnel - regardless of geographic location - delivers the timely attention you require.

Whatever your access hardware needs, no one offers more. Contact a Southco representative today, to discover all the possibilities.



**Global Corporate Headquarters & Customer and Technical Support Centre**  
**Concordville, PA · USA**  
 Tel: (1) 610 459 4000  
 Fax: (1) 610 459 4012

**Canada** Tel: (1) 905 855 0309  
**Mexico** Tel: (1) 877 821 0666

**Manufacturing & Stocking Locations**  
 Chihuahua, Mexico  
 Concordville, Pennsylvania  
 Honeoye Falls, New York  
 Tecate, Mexico  
 Rockledge, Florida

**Europe Customer & Technical Support Centre**  
**Worcester · UK**  
 Tel: (44) (0) 1905 346722  
 Fax: (44) (0) 1905 346723

**Austria** Tel: 0800 281 831  
**France** Tel: 0800 912 756  
**Germany** Tel: 0800 1800 380  
**Italy** Tel: 800 780 953  
**Spain** Tel: 900 968917  
**Sweden** Tel: 020 790 366  
**UK & NI** Tel: 0845 117 9222

**Manufacturing & Stocking Locations**  
 Farnham, UK  
 Worcester, UK

**Asia Customer & Technical Support Centre**  
**Hong Kong · China**  
 Tel: (852) 3127 1503  
 Fax: (852) 3127 1541

**China** Tel: 800 820 0272  
**Japan** Tel: 00531 121672  
**Korea** Tel: 0505 777 1234  
**Malaysia** Tel: 1800 801 119  
**Singapore** Tel: 800 18 11016  
**Taiwan** Tel: 0800 558 015

**Australia Customer Service and Distribution Centre**  
**Tullamarine · Victoria 3043 · Australia**  
 Tel: (61) 03 9330-5000 · Fax: (61) 03 9330 - 5099

**India Customer Service and Technical Support Centre**  
**Taluka Shirur · Pune 412208 · India**  
 Tel: (91) (21) 3867 0538 · Fax: (91) (21) 3867 0588

**Manufacturing & Stocking Locations**  
 Hong Kong, China      Shanghai, China  
 Melbourne, Australia      Shenzhen, China  
 Pune, India      Tokyo, Japan  
 Seoul, South Korea



GLOBAL DESIGN TECHNOLOGIES S.L.  
 Avenida de la Industria, 13 Planta 1 Oficina 2  
 28108 Alcobendas Madrid ESPAÑA  
 TEL 902 36 15 02 - FAX 902 36 15 03