



68 Cam Latch

Small · T-Handle · Adjustable grip

• **Robust design**

Material and Finish

Zinc alloy and steel, zinc plated

Performance Details

Max. static load: 1100 N (250 lbf)

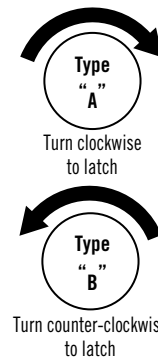
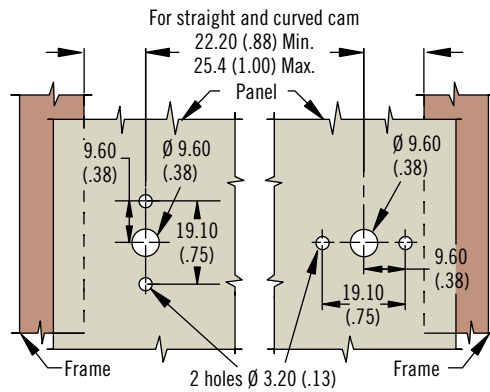
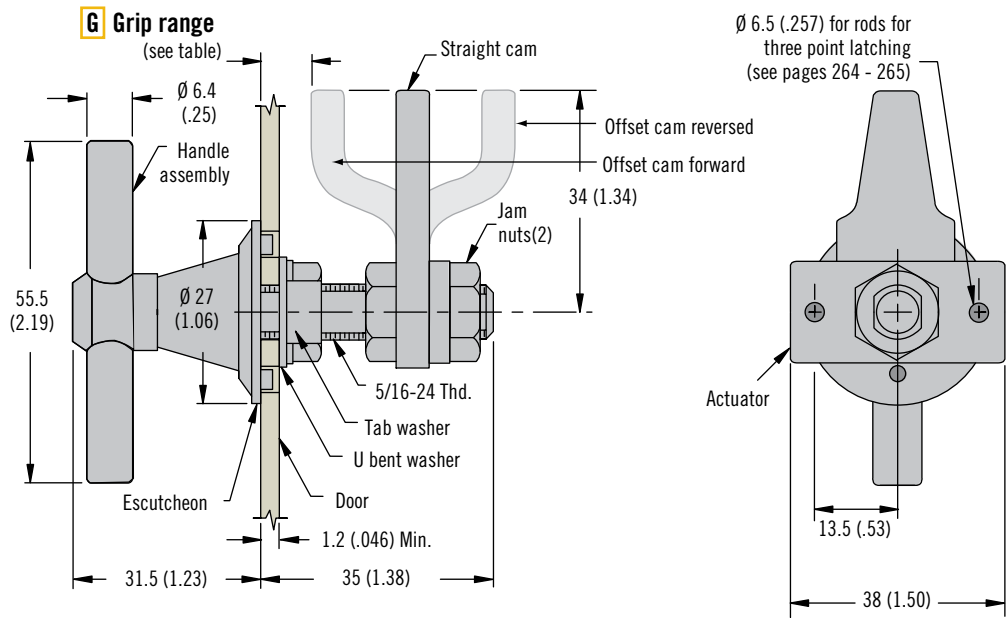

Part Number Selection

Grip	Min.	Max.	Cam Type
1	0 (0)	12.7 (.50)	Offset cam forward position
	25.4 (1.00)	38 (1.50)	Offset cam reversed position
2	12.7 (.50)	25.4 (1.00)	Straight cam

68 - 50 - 30 G - F

F Finish
 10 Chemical protective film
 20 Chrome plated



www.southco.com/68

Dimensions in millimeters (inch) unless otherwise stated

68 Cam Latch

Medium · T-Handle · Adjustable grip

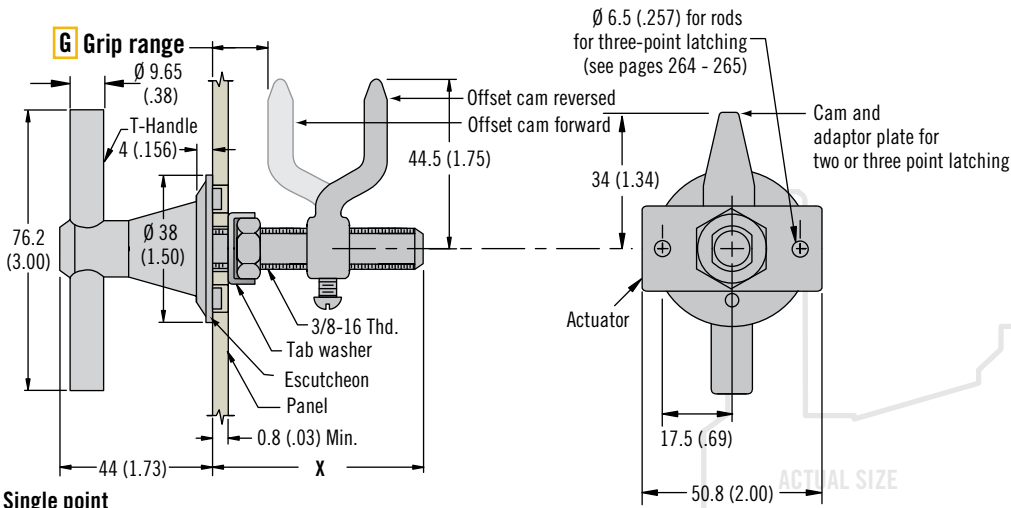
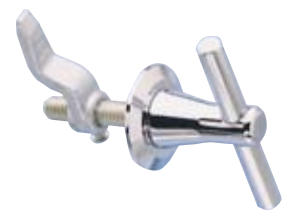

A Single point

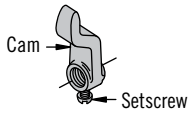

A Three point

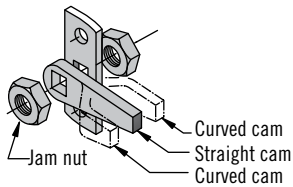

A Inside release

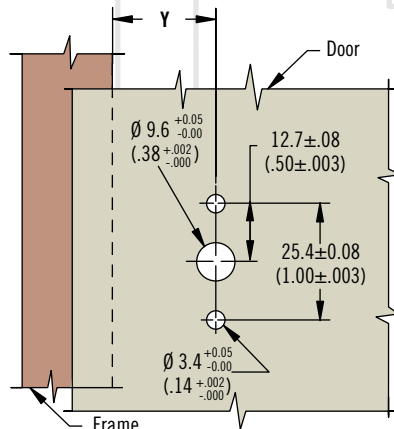
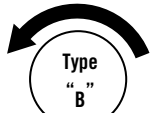
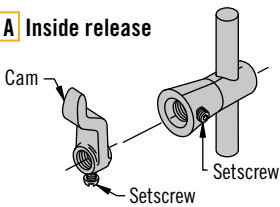

- Robust design
- Optional internal actuation

Material and Finish

Zinc alloy and steel, zinc plated

Performance Details

Max. static load: 1100 N (250 lbf)

Installation Notes

T-handle orientation and operation:

1. Handle parallel to the edge of door

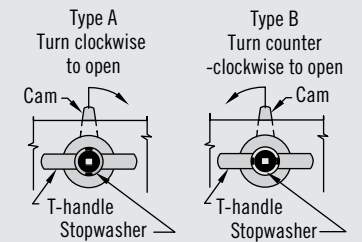

2. Handle perpendicular to edge of door

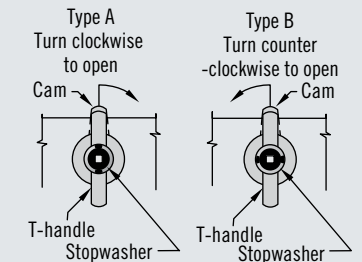

Part Number Selection

A Assembly

- 1 Single point
- 3 Three point
- 4 Inside release

68 - 10 - A 0 G - F

F Finish

- 10 Zinc plate bright chromate
- 20 Chrome plated

Assembly	G Grip	Grip Range		X	Y	Cam Type
		Min.	Max.			
Single point	1	3.2 (.13)	25.4 (1.00)	46.4 (1.83)	31.8 ± 3.2 (1.25 ± .13)	Offset cam forward position
		25.4 (1.00)	50.8 (2.00)			Offset cam reversed position
Three point	1	1.6 (.06)	19.8 (.78)		28.6 ± 1.6 (1.13 ± .06)	Offset cam forward position
		14.3 (.56)	32.5 (1.28)			Offset cam reversed position
	2	27 (1.06)	45.2 (1.78)			Straight cam
Inside release	1	3.2 (.13)	25.4 (1.00)		65 (2.56)	31.8 ± 3.2 (1.25 ± .13)
		25.4 (1.00)	50.8 (2.00)	Offset cam reversed position		



68 Cam Latch

Medium · Folding bail handle · Adjustable grip

- Robust design
- 90° rotation

Material and Finish

Zinc alloy and steel, zinc plated

Performance Details

Max. static load 890 N (200 lbf)

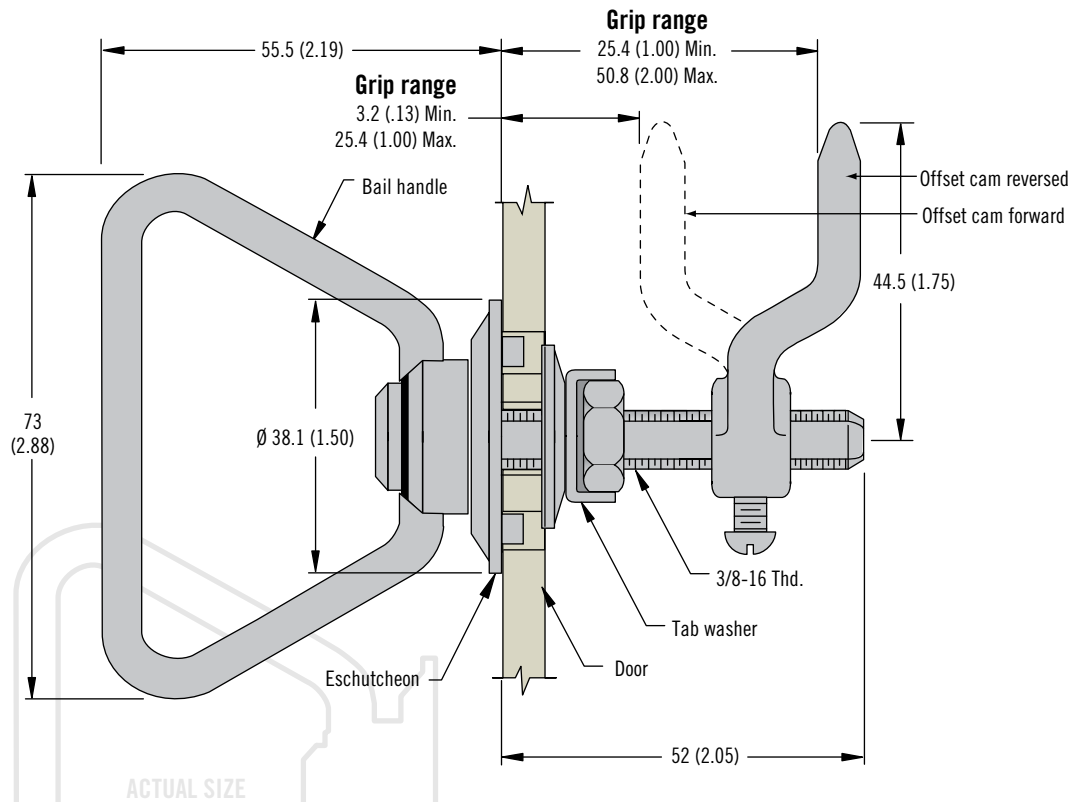

Bail Handle Orientation and Operation (Shown in latched position)

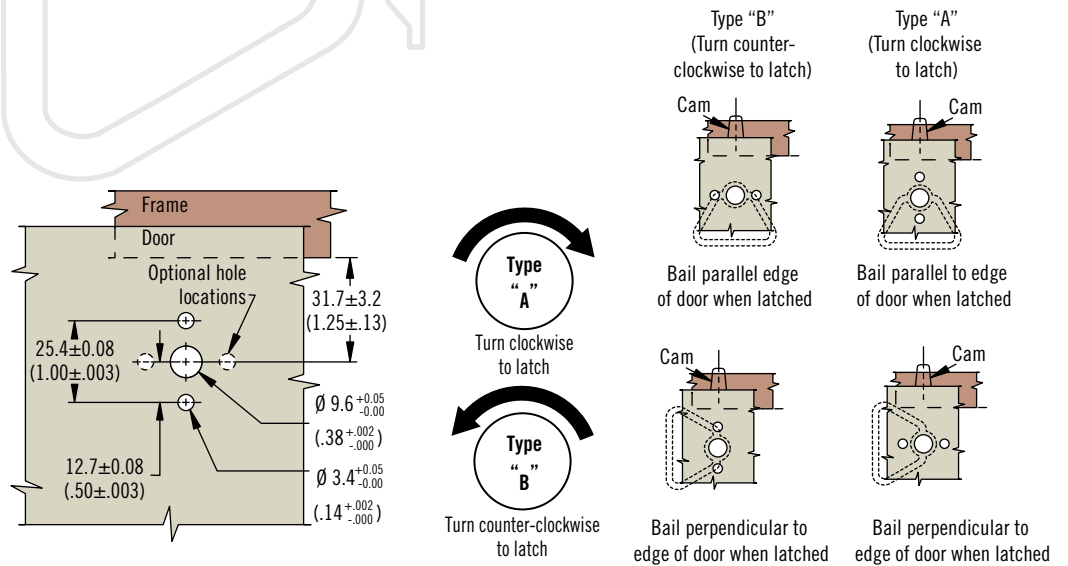

Part Number Selection

68 - 20 - 101 - **F**

F Finish
 10 Zinc plate bright chromate
 20 Chrome plated

68 Cam Latch

Large · T-Handle · Adjustable grip

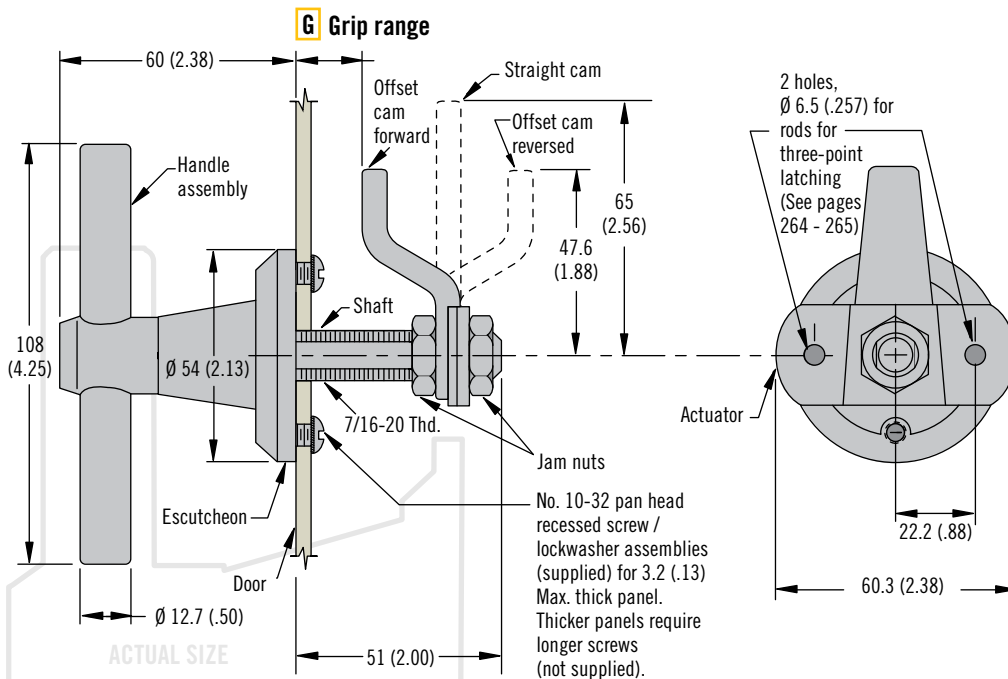

- Robust construction
- 90° movement

Material and Finish

Zinc alloy and steel, zinc plated

Performance Details

Max. static load 1300 N (1300 lbf)

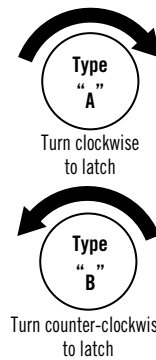
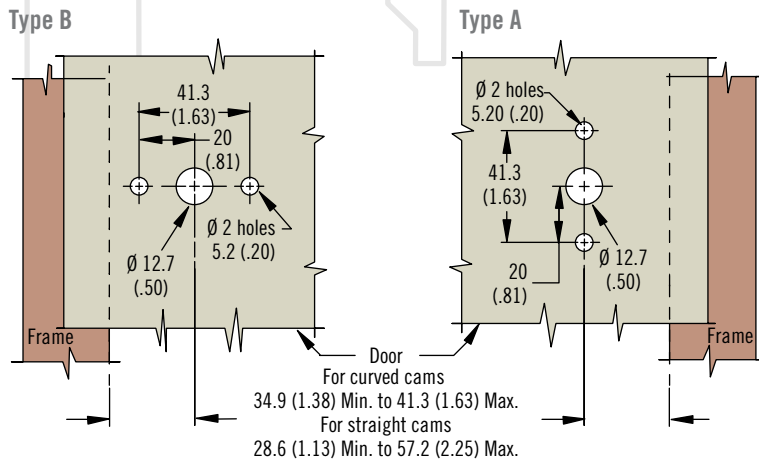

Part Number Selection

68 - 70 - 30 **G** - **F**

G Grip	Min.	Max.	Cam Type
1	0 (0)	19 (.75)	Offset cam forward position
	6.4 (.25)	38 (1.50)	Offset cam reversed position
2	25.4 (1.00)	57 (2.25)	Straight cam

- F** Finish
- 10 Chemical protective film
 - 20 Chrome plated

Southco® Pawl/Cam Action Latches

Bail-handle Series, Large Size

- **Restricted 90° rotation**
- **Mounts from inside the panel so no mounting hardware is visible**
- **Detents hold the handle in the open and stored positions**
- **Clockwise or counterclockwise operation**



Material and Finish

ESCUTCHEON and STOP WASHER: Die-cast zinc, chemical protective film or chrome plated (see table).

BAIL HANDLE: 1008 Steel, zinc plate bright chromate or chrome plated (see table).

SHAFT: Low carbon steel, zinc plate bright chromate or chrome plated (see table).

PAWL, ACTUATOR, BASE PLATE and TAB WASHER: 1010 Steel, zinc plate, chromate plus sealer.

JAM NUTS and MOUNTING SCREWS: Steel, zinc plate, chromate plus sealer.

WASHER: Spring steel, zinc plate, chromate plus sealer.

Product Strength Guidelines

(To assist in your product selection; samples are available for your evaluation.)

Average ultimate load: 1300 N (300 lbs.)

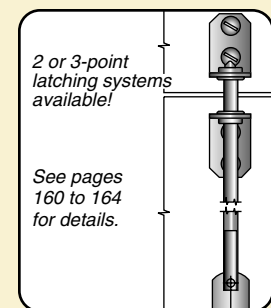

millimeter (inch)
millimeter
(inch)

Dimensions without tolerances are for reference only.

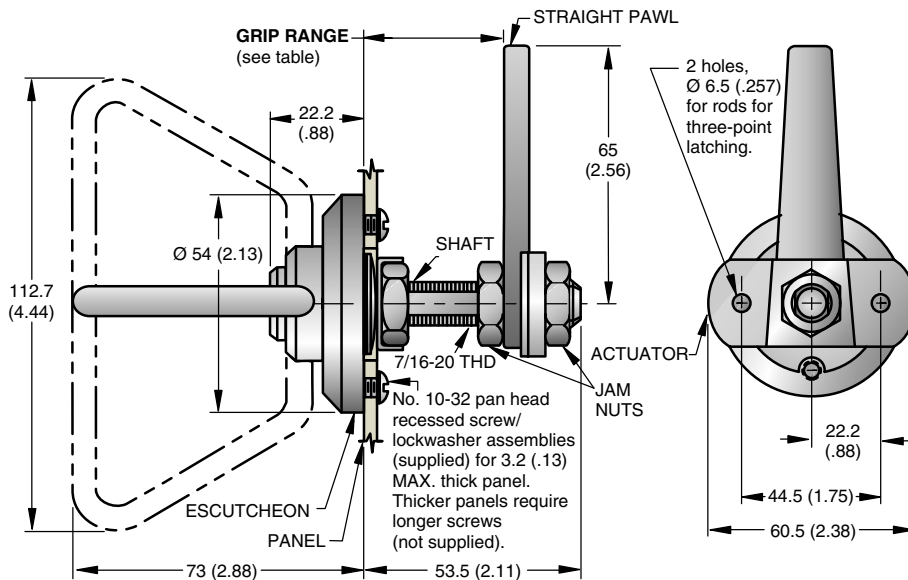

GRIP RANGE		PART NUMBERS	
Handle Assembly finish			
MIN.	MAX.	Zinc Plate Bright Chromate	Chrome Plated
16 (.63)	36.5 (1.44)	68-80-302-10 •	68-80-302-20 •

Latch is shipped unassembled, one unit per package.

Installation and Operation

1. Prepare panel as shown.

Type "B" Operation
Turn bail handle counterclockwise to latch.

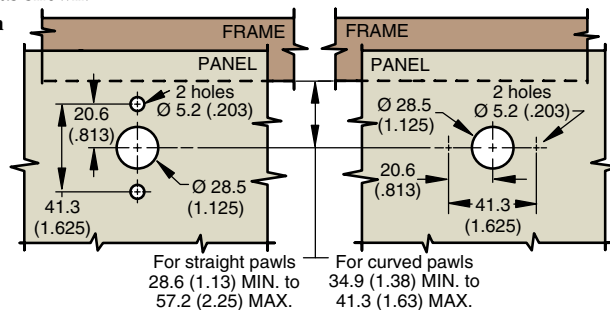

Type "A" Operation
Turn bail handle clockwise to latch.

2. Assemble as shown.

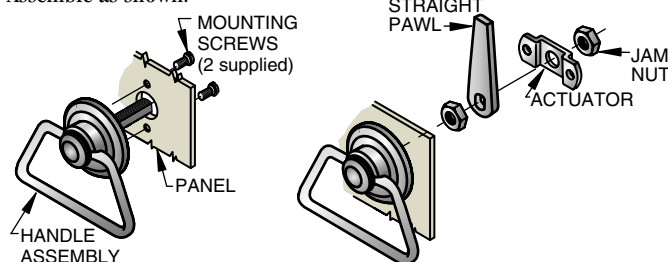

3. Adjust pawl to GRIP measurement. Use two wrenches to tighten.

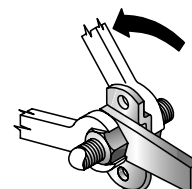

Note: the handle is always perpendicular to the pawl.