



ONURFIX®

ARC 800

Power Unit

93-10-0702A



Operating Manual

Customer Service in Germany:

HBS Bolzenschweiss-Systeme GmbH & Co. KG
Felix-Wankel-Strasse 18
85221 Dachau / Germany

Phone +49 (0) 8131 511-0
Fax +49 (0) 8131 511-100
E-mail post@hbs-info.com
Web www.hbs-info.com

ARC 800 Operating Manual, Issue 03/2008 Order No. BA 93-10-0702A

Copyright:

The information contained herein may not be copied, reproduced, adapted, merged, translated or used without the prior written consent of the copyright owner.

Adaptations, errors and technical modifications reserved without prior notice.

© HBS Bolzenschweiss-Systeme GmbH & Co. KG

Dear customer,

Thank you very much for purchasing a power unit from HBS Bolzenschweiss-Systeme.

We from HBS wish you always successful working with this stud welding unit.

We ask you to observe the following points:

- Store the operating manual in a way that it can always be accessed by the operator.
- Let the operator sign before starting up that he has read and completely understood the operating manual.
- This operating manual applies only to this stud welding unit.
- Protect the stud welding unit from unauthorized use.
- The stud welding unit must only be operated by trained personnel.
- Let an electrician check whether the wall sockets where you want to connect the related stud welding unit, are properly fused and grounded.
- Inform our customer service in case of malfunction.
- In case of accident, inform a physician and the responsible official body.



THREAT TO LIFE!

Persons fitted with a pace maker must not operate the stud welding machine.



MAGNETIC FIELDS!

During stud welding, strong electro-magnetic fields are generated. Do not weld in the vicinity of the electrical equipment which could be affected.

Safety instructions are a delicate subject. Anybody who handles a stud welding unit, whether it is the welding gun or the power unit, should be familiar with them, because improper use of stud welding units can be dangerous to life.

For your own sake you should know the safety instructions for operating your HBS stud welding units inside out.

In addition to the protection of your health and the capital value of the enterprise, the safety instructions are intended to clarify any responsibilities, which arise from ownership and operation of the equipment.

This chapter of the operating manual offers you clear and easy to understand information for the safe operation of your HBS stud welding unit.

Your power unit may differ in some details from the captions in this manual. This has no effect on the operation of the welding machine.

Should you have questions about this manual or in case you want to order some more copies, please provide the order number listed in the foot line.

Important reminder:

Data and information herein were collected with greatest care. Although we did our very best to correctly update any information up to the time of delivery, there is no guarantee in respect of errors.

If you should detect errors or mistakes right in this manual, please contact us:

HBS Bolzenschweiss-Systeme GmbH & Co. KG

Felix-Wankel-Strasse 18

85221 Dachau / Germany

A feedback blank is provided in the appendix.

Table of Contents

1	General	9
1.1	Guide to this Operating Manual	10
1.2	Safety Symbols	11
1.3	General Safety Instructions	12
1.4	Intended Use	12
1.5	Transportation, Packaging, Storage	13
1.6	Accompanying Documents	13
1.7	Markings	14
2	Delivery	15
3	Starting-up	16
3.1	Requirements of Workplace	16
3.2	Connecting the Power Unit to the Primary Power Supply	17
3.3	Connecting the Welding Gun to the Power Unit	18
3.4	Ground Connection	19
3.5	Shielding Gas Connection	20
3.6	Change Working Place	20
4	Function	21
4.1	Components of the Power Unit	21
4.1.1	Power Unit	21
4.1.2	Control Unit	21
4.2	Keyboard and Display	22
5	Stud Welding Procedure	23
5.1	Safety Instructions	23
5.2	Functional Principle of Stud Welding	26
5.2.1	Drawn-Arc stud Welding with Ceramic Ferrule	28
5.2.2	Drawn-Arc Stud Welding with Shielding Gas	28
5.2.3	Short-Cycle Drawn-Arc Stud Welding with Shielding Gas	29
5.2.4	Drawn-Arc Capacitor-Discharge Stud Welding	30
5.3	Welding Preparation	30
5.4	High-strength Welds	30
5.5	Determination of Welding Parameters	30

5.6	Switching on the Power Unit	32
5.6.1	Adjusting the Welding Time	33
5.6.2	Adjusting the Gas Pre-Flow Time	33
5.7	Welding Procedure	33
5.8	Checking the Quality of the Weld	34
5.8.1	Visual Inspection	35
5.8.2	Bending Test	35
5.8.3	Arc Blow Effect	37
5.9	Malfunctions and Corrective Actions	38
5.10	Welding Elements	39
6	Switching off the Power Unit	42
6.1	Temporary Switching off	42
6.2	Disposal	42
7	Care and Maintenance	43
7.1	Safety Instructions	43
7.2	Regular Maintenance Operations	43
7.3	Tools to be Used	43
7.4	Open the Power Unit	44
8	Appendix	45
8.1	Technical Data	45
8.2	Spare Parts	46
8.3	Electrical Circuit Diagram	62
8.4	Environmentally Admissible Disposal	63



Glossary	64
Regulations and Standards	65
Further Instructions	67
Guarantee Clauses	68
EU-Statement of Conformity	69
Confirmation	70
Feedback	71
Service & Support	72
Index	73

1 General

Persons addressed by this operating manual

This operating manual is written for operators, personnel of the end user, and authorized service technicians. It provides you with all necessary information to operate the power unit.

Required user qualification

The power unit must only be operated by qualified personnel .

- ◆ Let the power unit only be operated by persons who
 - are qualified through a suitable training according to the current standards (see appendix),
 - are properly instructed,
 - are physically and intellectually suitable,
 - can be expected to reliably fulfill the requested job.

What else must the owner observe?

- ◆ Make sure that this operating manual is always in reach of the stud welding unit.
- ◆ Read the entire manual before operating the power unit.
- ◆ Strictly observe the safety instructions.
- ◆ Before starting up the power unit, let the operator sign the confirmation that he/she has read and fully understood the operating manual (see appendix).
- ◆ Do not commence stud welding until you have understood all operating processes.
- ◆ Contact us if there are any doubts on certain operating procedures.
- ◆ Protect the power unit against unauthorized use.
- ◆ Inform our service in case of malfunction.

Based on this operating manual, a company specific work order, as well as a company specific maintenance instruction must be drawn up. The company specific work order must consider the special user conditions in your company.

Make sure that operators of the welder are provided with and wear personal protective equipment, e.g. protective goggles, gloves, shoes, ear protection etc.

Owners and operators make sure that the power unit is only used as directed.

- ◆ During any activity such as transportation, set-up, (re-)assembly, production, maintenance etc. observe the information given in this operating manual.

1.1 Guide to this Operating Manual

This operating manual provides you with the following information

"Delivery"	in Chapter 2
"Starting-up"	in Chapter 3
"Functional Principle"	in Chapter 4
"Stud Welding Process"	in Chapter 5
"Switching off the Power Unit"	in Chapter 6
"Care and Maintenance"	in Chapter 7
Technical Data and much more	in Appendix

THREAT TO LIFE and risk of serious health and material damage in case of improper use of the power unit. Observe all notes in this operating manual.



Note for qualified operators (see chapter 1).



All instructions contained in this manual must also be observed by qualified operators.

The welding process and the sequence of procedures to carry out a weld are described in chapter 5.

1.2 Safety Symbols

Symbols and markings used in this operating manual mean:



Threat to life or risk of personal injury



Risk of material damage



Ban for persons fitted with a pace maker



Warning of dangerous electrical voltage



Warning of electromagnetic fields



Wear protective clothes



Wear protective goggles



Wear ear protection



Additional tips for operation and service safety



Prompt



List

1.3 General Safety Instructions



Improper operation of the power unit is LIFE-THREATENING!

Threat to life

- by electric shock and arc
- by toxic vapors and airborne particles
- by red-hot metal spatters (fire risk)
- by blow-up of explosive gases and materials
- by strong magnetic fields for persons fitted with a pace maker

In addition, through improper use damage to the stud welding unit and to material can be caused. For details, see chapters 1, 3 and 5.

1.4 Intended Use



Danger

Warning: Unauthorized interference with the stud welding unit as well as unauthorized alteration of the stud welding unit are prohibited and result in complete cancellation of any guarantee and liability claims against HBS.



Operation of the power unit is only allowed with HBS welding guns, this clause is also part of "use as directed".

The power unit is intended to weld welding elements according to actual standards (see chapter 5 and appendix). Any other use is regarded as not used as directed. The manufacturer is not liable for damages resulting from the stud welding unit not used as directed. Any risk is carried by the user.

The power unit is designed according to specific standards and accident prevention regulations. Basics are European Union guidelines and in Germany valid standards. *Please note that in your country additional standards and safety conditions (especially rules for accident prevention) may differ from the standards mentioned in this operating manual.* The power unit was manufactured to the latest developments in technology and is regarded as safe to operate (place of operation see section 8.1).

The welding guns A 12, A 16, AI 06 and CA 08 can be connected to the HBS power unit ARC 800. For details please contact the HBS customer service (address see page ii).

- ◆ Check in any case the operating manual of the HBS welding gun whether this power unit can be used.

Observing the operating manual of the used welding gun is also part of the "use as directed".

1.5 Transportation, Packaging, Storage

HBS delivers products in a specific transport package.

- ◆ Save the undamaged packing. Ship and transport the device only in its original packing.

Right before delivery, the power unit is once again checked for proper functioning and a control mark is attached. When receiving the delivery, check everything for damages and completeness. If damages occurred during transportation or components are missing, inform the manufacturer or the haulier immediately (see page ii).

Proper functioning of the power unit can only be checked before starting-up by visual inspection (visible damage).

The following items are to be observed if the power unit is not to be put into operation immediately after delivery.

- The power unit must be stored in a secure place
- The power unit must be protected against humidity, dust, metallic dirt.
 - Storage temperature: -5 °C to +50 °C
 - Relative humidity: 0% to 50% at +40 °C
0% to 90% at +20 °C
- ◆ If you resell the power unit, please provide us with the name and postal address of the new owner so that we can advise them of any changes to the operating manual.

1.6 Accompanying Documents

In addition to this operating manual, you must observe the operating manual of the welding gun as well as applicable accident prevention and safety instructions.

1.7 Markings

There are various markings and safety symbols attached to your power unit (see section 8.1).

- ◆ Make sure that all markings remain clearly visible.

Type plate

The type plate contains the following data:

Manufacturer

Type

OrderNo./SerialNo.

Primaryvoltage

Fuse

Powerconsumption

Cooling class

Protection class

Date

Safety symbols



Replace illegible or damaged markings



Bei Öffnen des Gehäuses
Stromschlaggefahr!
Vor dem Öffnen der Maschine
den Strom abtrennen!
Avant d'ouvrir l'appareil
retirer la fiche secteur.
Après de séparer et
électriser l'acier et l'acier.

Before opening machine disconnect mains



Observe operating manual



Warning of dangerous electrical voltage

- ◆ Secure the following safety symbols in the area of welding place:



2 Delivery

The basic equipment of your power unit contains the following components:

No. of pieces	Part	Type	Order No.
1	Power unit	ARC800	93-10-0702A
1	Operating manual	ARC800	BA93-10-0702A

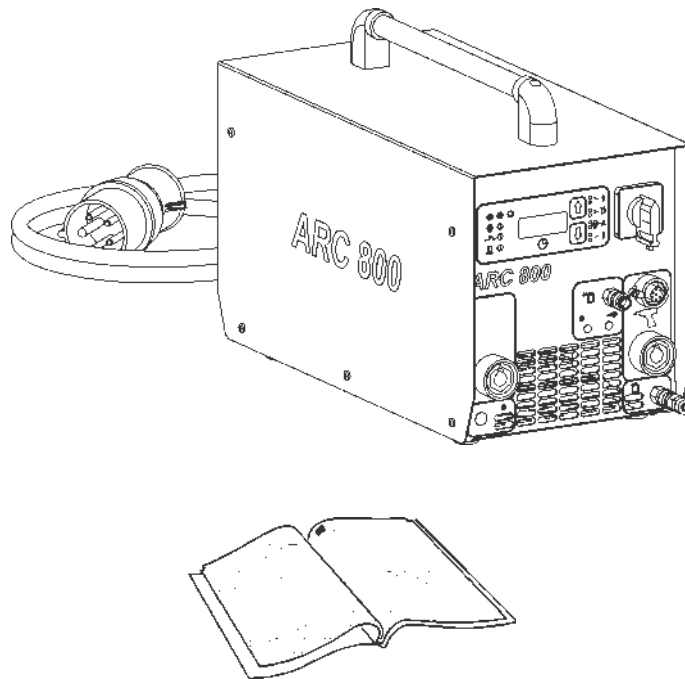

3 Starting-up

In this chapter you learn what to observe during setting-up and starting-up of the power unit.

3.1 Requirements of Workplace



Vapors and airborne particles may occur during stud welding operations. Especially with surface treated materials, toxic vapors may be produced.

- ◆ Ensure that a fume extraction is available and that the room is adequately ventilated according to accident prevention regulations.
- ◆ If possible, do not weld in rooms which are lower than 3 meters.
- ◆ Special regulations apply for confined rooms, according to accident prevention regulations of the official bodies (see appendix).
- ◆ Weld only in adequate distance from combustible articles or liquids.
- ◆ Before you start welding, remove any combustible articles or liquids in vicinity of the workplace.
- ◆ Make sure that a fire extinguisher is within reach.
- ◆ Never weld in rooms exposed to risk of explosion.
- ◆ Do not set-up the product in the vicinity of any apparatus or equipment which is sensitive to welding spatters.
- ◆ Do not set-up the product in the vicinity of any apparatus or equipment which is sensitive to magnetic fields.
- ◆ Set-up the power unit:
 - on a stable, clean, and level surface
 - so that no-one is influenced or injured by welding spatters
 - so that all cables and primary lines are protected from being damaged
 - so that nobody will trip or fall over the cables or connection lines.
- ◆ Ensure that air is able to circulate freely through the housing.



If heat is built-up inside the housing caused by bad air circulation, the stud welding unit will be seriously damaged.

- ◆ Secure the following safety symbols in the area of welding place:



THREAT TO LIFE to persons fitted with a pace maker

Strong electro-magnetic fields occur in the vicinity of the stud welding unit during welding. Such fields may affect the proper function of a pace maker. Thus persons equipped with a pace maker must not operate the stud welding unit and must not stay in its vicinity during welding.



During the actual welding process, you must expect red-hot welding spatters, possibly liquid spatters, a flash, and a loud bang > 90 dB (A). Alert any colleagues who are occupied in the vicinity of the welder. Wear your personal protective equipment according to actual standards (see appendix).

3.2 Connecting the Power Unit to the Primary Power Supply

- ◆ Compare the primary voltage specified on the type plate with the voltage provided by your primary power supply. The type plate is located on the backside of the power unit.



Never connect the welder to a power supply with a voltage different from the voltage indicated on the type plate.

- ◆ Check the current consumption specified on the type plate with the fuse rating of your primary power supply.
- ◆ Have an electrician check whether the outlet to which you want to connect the power unit is correctly grounded.
- ◆ Switch off the power unit.
- ◆ Insert the primary plug into the checked outlet.

3.3 Connecting the Welding Gun to the Power Unit



Switch off the power unit. In this way, you avoid any risk of electrical shock.

- ◆ Plug the welding cable of the welding gun into the socket of the power unit.
- ◆ Press-in the plug and twist firmly clockwise.

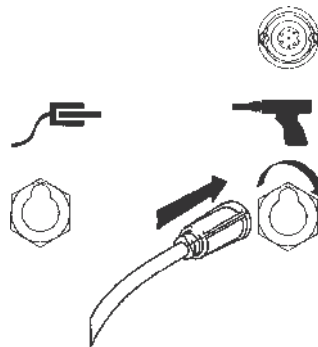

The connection is not secured against working itself loose! Check the plug connections regularly to ensure that they are properly locked. In case of loose connection, heat may build up in the plug and may destroy the entire plug connection.

- ◆ Plug the control cable in the connector of the power unit.

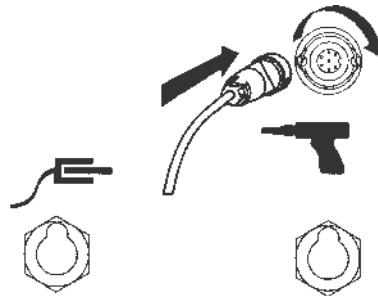

- ◆ Twist the retaining nut of the control cable connector clockwise to secure the connection.



The welding gun cables must not be coiled during welding. Coiled cables work as a coil and may negatively affect the welding result. Before welding, lay out the cables lengthwise.

- ◆ Fix the cables. Strong magnetic fields occur during welding which may cause a movement of the cables. This may cause a slackness of the connections.

3.4 Ground Connection

- ◆ Plug the ground cable in the connector of the power unit.

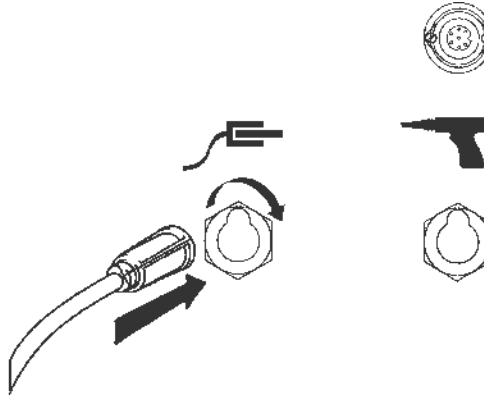

- ◆ Press in the plug and twist firmly clockwise.



The connection is not secured against working itself loose! Check the plug connections regularly to ensure that they are properly locked. In case of loose connection, heat may build up in the plug and may destroy the entire plug connection.

- ◆ Remove any rust, paint, or contaminants from the workpiece in the areas where you intend to connect the ground cables.
- ◆ Connect the ground clamps to the workpiece as securely as possible.

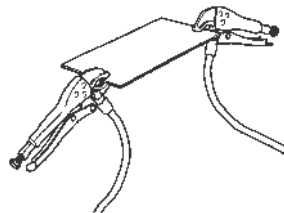

Take care to ensure good contact and symmetrical connection. The welding location must lie directly between the two ground clamps.

3.5 Shielding Gas Connection



Observe the standards (see appendix) when handling the shielding gas bottles.

Connect the shielding gas bottle as follows:

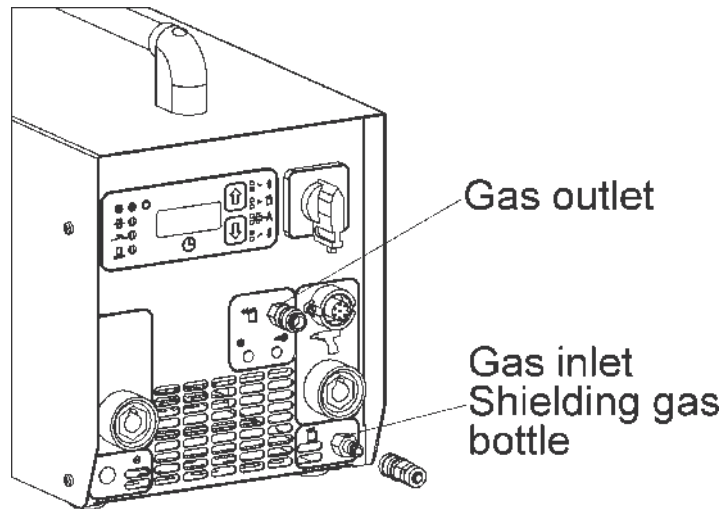

- ◆ Connect the gas hose of the shielding gas bottle to the gas inlet of the power unit.
- ◆ Connect the gas hose of the welding gun to the gas outlet.
- ◆ Set the flow meter of the shielding gas bottle to 8 - 16 liters/min.



Minimum flow rate for stud welding with shielded gas is 8 l/min.

A gas mixture of 82% Argon (Ar) and 18% carbon dioxide (CO₂) is mainly used for stud welding.

3.6 Change Working Place



Switch off the power unit. In this way, you avoid any risk of electrical shock.

- ◆ When you move your workplace, disconnect the welding gun and the ground cables from the power unit. Proceed in reversed sequence as described in sections 3.2, 3.3, 3.4 and 3.5.
- ◆ After changing the workplace, check the welding gun and the ground cables for possible damage or missing components.

4 Function

In this chapter you learn more about the design of the power unit and how to use the various setting options.

4.1 Components of the Power Unit

4.1.1 Power Unit

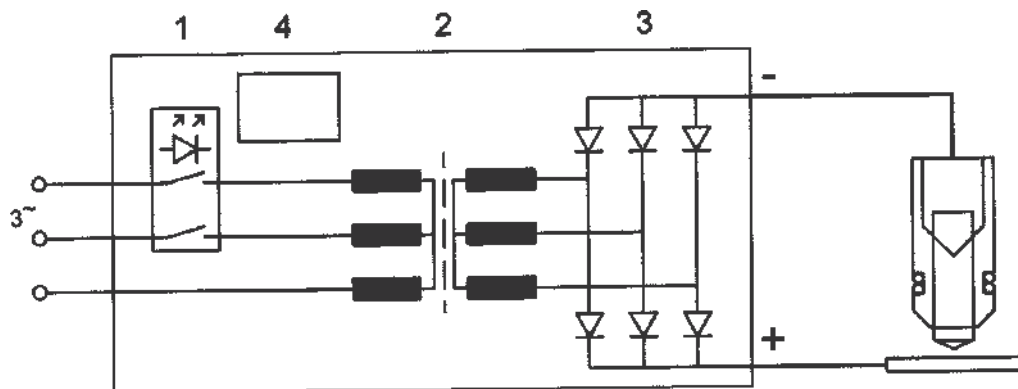

The power unit consists of the main assemblies

- | | | | |
|-----|--------------------|-----|--------------|
| 1 - | Solid-State-Relais | 2 - | Transformer |
| 3 - | Rectifier | 4 - | Control unit |

Mains alternating current is transformed in the transformer (2) and converted in the rectifier (3).

4.1.2 Control Unit

The control unit synchronizes the mechanical sequence (lifting the welding element) with the electronic control (ignition of pilot arc, ignition of main arc, sequence of welding time). The welding time is stepless adjustable.

4.2 Keyboard and Display

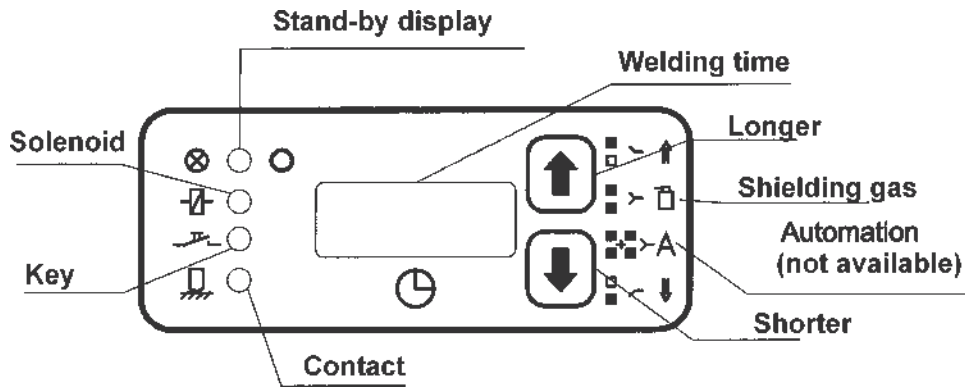

Stand-by display green = Ready for welding
 Stand-by display red = Locked

How to use displays and keys is described in section 5.6.

5 Stud Welding Procedure

This chapter contains the basics of stud welding, how you must actually proceed, and what must be observed. You learn to select correct welding parameters and which welding elements can be used.

5.1 Safety Instructions



Improper operation of the power unit is LIFE-THREATENING!

Threat to life

- by electric shock and arc
- by toxic vapors and airborne particles
- by red-hot metal spatters (fire risk)
- by blow-up of explosive gases and materials
- during welding of hollow parts
- by strong magnetic fields to persons fitted with a pace maker



THREAT TO LIFE by electrical shock and arc

During the actual stud welding process, do not touch the welding elements, chuck, or retaining nut nor any electrically conductive parts in their vicinity. These are all electrically life.

Step onto an insulating mat, if you have to weld under the following conditions:

- in confined rooms with electrically conductive walls
- under confined conditions between or on electrically conductive parts
- with restricted freedom of movement on electrically conductive parts
- in wet or hot areas

When operating the stud welding unit, you must not wear any metallic jewellery incl. wrist watches, especially on hands. Remove any electrically conductive or electro-magnetically sensitive parts from your body before you start welding. In this way, you avoid the risk of damage by electric shock or influence of electromagnetic fields.

**THREAT TO LIFE by toxic vapors and airborne particles**

Toxic vapors and airborne particles may occur during stud welding operations, especially with surface treated materials.

Ensure that a fume extraction is available that the room is adequately ventilated according to accident prevention regulations.

If possible, do not weld in rooms which are lower than 3 meters. Special regulations apply for confined rooms according to accident prevention regulations of the official bodies of your country (see appendix).

**THREAT TO LIFE by red-hot metal spatters (fire risk)**

Make sure that a fire extinguisher is within reach.

Do not wear clothes, which are contaminated with combustible materials like oil, grease, kerosene etc. during welding.

Always wear your personal protective equipment such as:

- protective gloves to current standards (see appendix),
- safety goggles with a window providing protection class 2 to current standards (see appendix),
- non-combustible clothes
- ear protection to current standards (see appendix),
- a protective apron over your clothes,
- a protective headgear when welding overhead.

Before starting to weld, remove all combustible articles and liquids in vicinity of the workplace.

Weld only in sufficient distance from combustible articles or liquids. choose a safety distance where there is no risk to injury from welding spatters!

**THREAT TO LIFE by blow-up of explosive gases and materials**

Never weld in rooms exposed to danger by explosion.

Special know-how is required when welding hollow parts which

- are combustible or support combustion,
- can emit toxic gases, vapors, or airborne particles,
- can explode.

Never execute such operations, if you do not have such special know-how.



Observe the regulations for accident prevention and standards which apply to the use of your stud welding unit (see appendix). The official Professional Association of your country will provide you with further information.

Please note that in your country additional standards and safety conditions (especially rules for accident prevention) may differ from the standards mentioned in this operating manual.



THREAT TO LIFE to persons fitted with a pace maker

Strong electro-magnetic fields occur in the vicinity of the stud welding unit during welding. Such fields may affect the proper function of a pace maker. Thus persons equipped with a pace maker must not operate the stud welding unit and must not stay in its vicinity during welding.



During the actual welding process, you must expect red-hot welding spatters, possibly liquid spatters, a flash, and a loud bang > 90 dB (A). Alert any colleagues who are occupied in the vicinity of the welder. Wear your personal protective equipment according to actual standards (see appendix).



MAGNETIC FIELDS!

During stud welding, strong magnetic fields are present. Do not weld in the vicinity of electrical systems and machines which could be affected.



Danger

Warning: Unauthorized interference with the stud welding unit as well as unauthorized alteration of the stud welding unit are prohibited and result in complete cancellation of any guarantee and liability claims against HBS.

- ◆ In case of any accidents whatsoever, advise a physician, your supervisor, and the official bodies immediately.

5.2 Functional Principle of Stud Welding

The face of a stud-shaped welding element and the opposite surface of the workpiece are molten by an arc. Stud welding is suitable for the welding of joining elements across the entire cross-section, mainly using pin-shaped metallic welding elements with metallic workpieces.

The various processes of arc stud welding are distinguished by:

- The method of weld pool protection (shielding gas - SG, ceramic ferrule - CF or no protection - NP)
- The length of welding time (standard ARC or short-cycled drawn-arc stud welding - SC)
- The energy source (welding rectifier supplied by mains, inverter, capacitor battery)

Variations for drawn-arc ignition are described in current standards and regulations (see appendix).

Drawn-Arc Stud Welding

The HBS stud welding unit operates by process of 'arc stud welding with drawn-arc ignition' according to the current standards (see appendix). The standards assign this method of joining pin-shaped elements with plane workpieces to the so called 'Arc Pressure Welding' (code BH).

Joining is carried out in plastic or liquefied condition of the welding zone. The process can be carried out mechanically or automatically, depending on the used welding guns/welding heads.

Generally, the positive pole of the power unit is connected to the workpiece. The welding element is manually or automatically inserted into the chuck of the welding gun or of the welding head. Then it is placed onto the workpiece - possibly equipped with a ceramic ferrule (see position 1). When the button of the welding gun is triggered, the automated welding process starts, which works as follows:

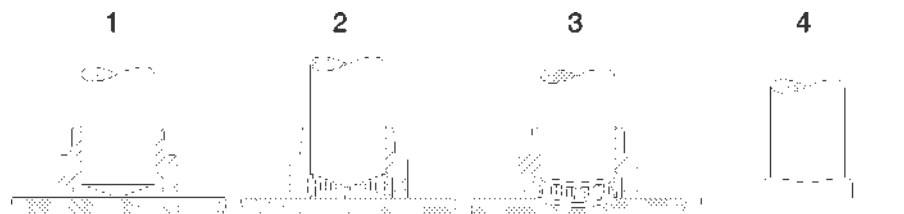

Pre-flow of shielding gas depending on set pre-flow time (only with shielding gas for weld pool protection).

- At the beginning of the welding process, the welding element (stud) in the welding gun is lifted clear off the workpiece by a lifting device (solenoid). An initial switched current triggers a pilot arc of a low current power (see position 2). Then the main arc ignites between the face area of the welding element and the workpiece.
- The main arc burns at the set current during the welding time preselected at the power unit. The selected welding energy must match the requirements of the selected welding element. The energy of the arc melts the face of the welding element and the workpiece (see position 3).
- At the end of the preset welding time, the stud is mechanically moved to the workpiece. On plunging into the weld pool, the two weld zones join and solidify. The contact of stud and workpiece extinguishes the arc in a short-circuit and the main current is switched off.
- The weld zones solidifies and cools down. The welding element is now welded to the workpiece over its entire cross-section of the welding element (see position 4). As soon as the weld metal is cooled down, the welding gun can be carefully withdrawn from the welding element. When using shielding gas, the shielding gas flow is switched off with the withdrawal of the welding gun. If a ceramic ferrule is used, it can be removed by light hammer blows.

The welding range of drawn-arc stud welding is about 3 to 25 mm diameter when using mild steel/stainless steel. Welding elements with rectangular cross-section should not exceed a ratio length : width of about 5 : 1. All technical information and adjustment values are based on the use of welding elements which correspond with current standards (see appendix).

Variations on Drawn-Arc Stud Welding

Item	Drawn-arc stud welding with ceramic ferrule/ring	Drawn-arc stud welding with shielding gas	Short-cycle stud welding with shielding gas	Capacitor-discharge stud welding with drawn-arc
Diameter welding element d [metric mm (imperial)]	3 - 25 (#4 or 12 gage to 1")	3 - 12 (16) (#4 or 12 gage to 1/2" (5/8"))	3 - 12 (#4 or 12 gage to 1/2")	2 - 8 (14 gage to 5/16")
Max. current I [A]	3000	2500	1500	5000
Welding time t [ms]	50 - 2000	50 - 2000	5 - 100	3 - 10
Energy source	Welding rectifier Welding transformer	Welding rectifier Welding transformer	Welding rectifier	Capacitor
Weld pool protection	Ceramic ferrule CF	Shielding gas SG	Shielding gas SG No protection NP	No protection NP
Material welding element	S 235 CrNi steel Aluminum (up to 12 mm/0,47")	S 235 CrNi steel Aluminum (up to 12 mm/0,47")	S 235 CrNi steel Brass (with shielding gas)	S 235 CrNi steel Aluminum, brass, copper
Workpiece surface	Metallic bright (rolling skin, rust film)	Metallic bright (rolling skin, rust film)	Metallic bright, galvanized, light oiled	Metallic bright, galvanized, light oiled
Min. thickness of workpiece	1/4 d min. 1 mm (0,04")	1/8 d min. 1 mm (0,04")	1/8 d min. 0,6 mm (0,02")	1/10 d min. 0,6 mm (0,02")
Adjustable parameters	Welding current I [A] = 80 x d (up to 16 mm/0,63")	Welding current I [A] = 80 x d (up to 16 mm/0,63")	Welding current I [A] = 100 x d (up to 12 mm/0,47")	Charging voltage
	Welding time t [ms] = 20 x d (up to 12 mm/0,47")	Welding time t [ms] = 20 x d (up to 12 mm/0,47")	Welding time	Ignition point/ lift
	Lift (arc length)	Lift (arc length)	Lift (arc length)	Spring pressure (plunging speed)
	Plunging depth	Plunging depth	Plunging depth	Plunging depth

5.2.1 Drawn-Arc stud Welding with Ceramic Ferrule

Drawn-arc stud welding with ceramic ferrule is used with welding elements of 3 to 25 mm diameter (preferably above 12 mm diameter) and with welding times of 50 to 2000 ms. It is generally suitable for all welding positions. When stud welding with ceramic ferrule, the welding position is PA (vertical). The major part of all applications applies to this procedure.

The ceramic ferrule (CF)

- prevents atmosphere from getting to the weld pool by a formation of metal vapor in the arc chamber
- stabilizes and concentrates the arc, thus decreasing the arc blow effect
- forms the melt under pressure to a weld collar and supports the weld pool on a vertical wall and overhead
- protects the welder from arc radiation and welding spatters



Normally, the ceramic ferrule is used for only one weld and is removed after solidification of the weld pool.

Standard welding elements and ceramic ferrules are described in several standards (see appendix). When using concrete anchors or shear connectors the front area can be plane constructed with a small pressed-in aluminum ball.

Studs with cone-shaped front area and aluminum ball



are preferably used with ceramic ferrule.

5.2.2 Drawn-Arc Stud Welding with Shielding Gas

Drawn-arc stud welding with shielding gas is used with welding elements for a diameter range of 3 to 12 (16) mm and with welding times from 50 to 2000 ms. Principally, it is suitable for all welding positions, however, it is preferably used in vertical position PA. With stud welding with shielding gas, the weld area is protected by shielding gas. The shielding gas, which is fed from outside through a gas control and an additional device, displaces the ambient atmosphere from the welding area and reduces considerably pore formation.



With steel and CrNi steel, the gas mixture 82% Ar and 18% CO₂ (DIN EN ISO 14175 – M21) is mainly used.



With aluminum, pure argon Ar 99,99 (DIN EN ISO 14175 – I1) or Ar-He mixtures (DIN EN ISO 14175 – I3) are used.

The shielding gas influences

- the arc and the melting behavior of welding element and workpiece,
- the development of the weld collar and the penetration shape via the surface tension.

With stud welding with shielding gas, the shape of the weld collar is not reproducible, as the shielding gas has no forming effects on the melt – different from a ceramic ferrule. And so an additional ceramic ferrule may be used in special cases.

The standard welding elements and ceramic ferrules for drawn-arc stud welding are described in several standards (see appendix). Welding elements with cone-shaped front area and without an aluminum ball are preferably used.

Studs with cone-shaped front area  preferably used under shielding gas.



With shielding gas, you should only weld in position PA (vertical) because due to gravity, the shielding gas cannot prevent flow of the molten metal.

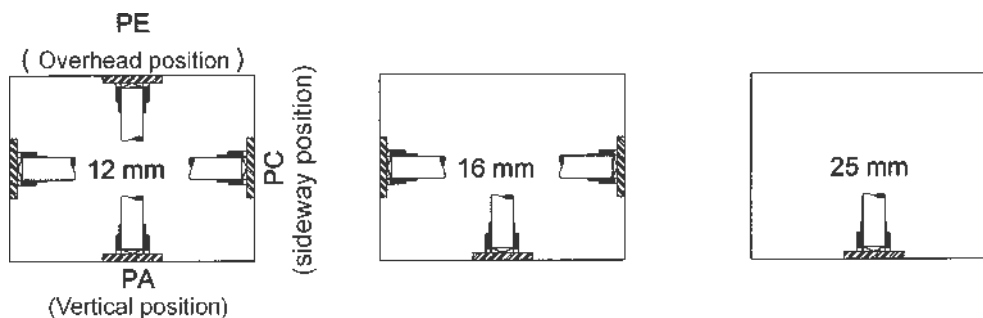

5.2.3 Short-Cycle Drawn-Arc Stud Welding with Shielding Gas

Short-cycled drawn-arc welding with shielding gas is used for welding elements within a diameter range of 3 to 12 mm (nominal diameter without flange) and welding times between 5 and 100 ms.

Due to the short welding times, the energy input and the weld pool are so small that also welding elements up to 12 mm diameter can be welded on thin workpieces.

Normally, welding elements with flange (according to current standards, see appendix) are used, which forms a larger welding area compared with the shaft diameter. In this way, higher tensional forces than in the stud shaft can be transmitted in spite of some pores in the weld zone. To minimize pore formation, the use of shielding gas for stud diameters upwards of 8 mm is recommended.

5.2.4 Drawn-Arc Capacitor-Discharge Stud Welding

With drawn-arc capacitor-discharge stud welding, the welding energy is taken from a capacitor. As a result, welding currents are very high and welding times (< 10 ms) very short. Normally, a weld pool protection is not required. The process is mainly used for welding elements in a diameter range of up to 8 mm.

5.3 Welding Preparation

- ◆ Read the safety instructions in chapters 1, 3 and 5.
- ◆ Observe the workplace requirements (chapter 3, "Starting-up").
- ◆ Check all cables and connections for proper condition.
- ◆ Replace immediately defective cables and cable connections to avoid electrical shocks.
- ◆ Check the chuck for proper seat (see operating manual of according welding gun).
- ◆ Before welding, make sure that the bellows are checked for damage and proper seat.

5.4 High-strength Welds

- ◆ The following must be removed both from the weld zone and the ground clamp connection areas:
 - paint, oil and any other impurities,
 - rust,
 - non-conductive coatings from surface treated workpieces.
- ◆ Weld to smooth and flat surfaces only.



For welding to pipes or punched plates consult our responsible application manager (address of customer service see page ii).

5.5 Determination of Welding Parameters

The adjustment of welding parameters on the power unit (e.g. welding time) or on the welding gun (e.g. lift) depends amongst others on

- material of the welding element
- diameter of the welding element
- material of the workpiece

The guidelines should be verified by test welding on the actual material and be changed if necessary. For an assessment of welding results, see sections 5.8 and 5.9.

Determination of welding time



Data given in the following table are only guidelines. They must be verified by trial welds on the actual material according to actual standards and DVS guidelines (see appendix). Before you use another lot of welding elements, carry out some trial welds to verify the parameter setting.

Setting of power unit

Designation (metric)	RD (imperial)	Eff. diameter (mm/inches)	Welding time in ms	Designation (metric)	UD / Pins (imperial)	Eff. diameter in mm (metric/mm)	Eff. diameter in mm (imperial)	Welding time in ms
M3	1/8"	not normed	-	3	#4 or 12 gage	3	#4 or 12 gage	20
M4	5/32"	not normed	-	4	#8	4	#8	35
M5	3/16"	not normed	-	5	#10 or 3/16"	5	#10 or 3/16"	50
M6	1/4"	4,7/0.19	45	6	1/4"	6	1/4"	75
M8	5/16"	6,2/0.24	80	8	5/16"	8	5/16"	130
M10	3/8"	7,9/0.31	130	10	7/16"	10	7/16"	200

Designation (metric)	PD (MD) (imperial)	Eff. diameter (mm/inches)	Welding time in ms	Designation (metric)	PS (FD) (metric)	Eff. diameter in mm (metric/mm)	Eff. diameter in mm (imperial)	Welding time in ms
M3	1/8"	not normed	-	M3	1/8"	4	#8	35
M4	5/32"	not normed	-	M4	5/32"	5	#10 or 3/16"	50
M5	3/16"	not normed	-	M5	3/16"	6	1/4"	75
M6	1/4"	5,4/0.21	60	M6	1/4"	7	0.28"	100
M8	5/16"	7,19/0.28	100	M8	5/16"	9	0.35"	170
M10	3/8"	9/0.35	165	M10	3/8"	11	0.43"	250

Setting of welding gun

Eff. diameter (metric/mm) (imperial)		Preferably under shielding gas		Preferably with ceramic ferrule	
		Plunging depth	Lift	Plunging depth	Lift
3	#4 or 12 gage	1,0	1,0	2,5	1,5
4	#8	1,0	1,0	2,5	1,5
5	#10 or 3/16"	1,0	1,0	2,5	1,5
6	1/4"	1,0	1,0	2,5	1,5
8	5/16"	1,0	1,0	2,5	2,0
10	7/16"	1,5	1,5	2,5	2,0
12	1/2"	1,5	1,5	3,0	2,0



Further notes on

- welding elements
- prestress at installation (tie load) and torque
- material combinations

see appendix and operating manual of the according welding gun.

5.6 Switching on the Power Unit



Improper operation of the stud welding unit is LIFE-THREATENING!
First read the safety instructions in chapters 1, 3 and 5.

- ◆ Insert the primary plug of the power unit into an appropriate socket.
- ◆ Switch on the power unit with the mains switch.

The digital display shows the adjusted charging voltage.

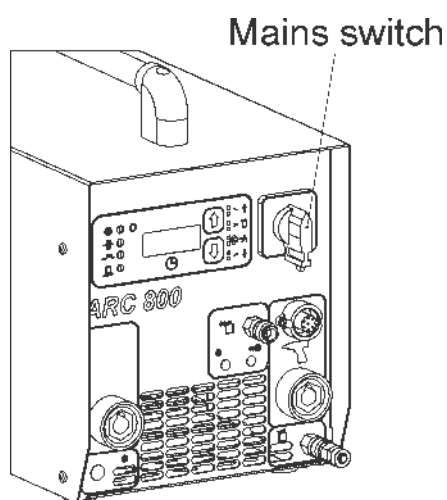

The digital display shows the adjusted welding time.

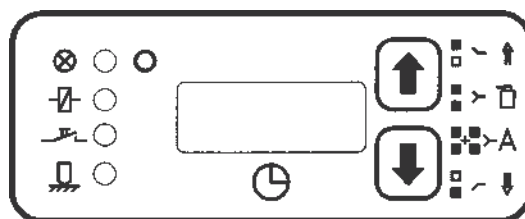

There is a luminous indication (LED) to the left of the display:

- Green – on, power unit is ready for welding
- ⊗ Red – on, power unit is locked
 - after welding, until there is electrical contact with the workpiece
 - if the power unit is overheated (the display shows 8 ... 2). After a short cooling period, the work can continue.
- |/ Green – lights if the solenoid of the welding gun is controlled
- |_ Green – lights if the welding gun button is triggered
- |_ Green – lights if there is electrical contact between welding element and workpiece.

5.6.1 Adjusting the Welding Time

- ◆ Refer to the table in section 5.5 for the required welding time matching your welding job.
- ◆ Set the welding time (digital display) with the arrow keys (higher – lower) on the display.

5.6.2 Adjusting the Gas Pre-Flow Time

If working with shielding gas, you have to set the gas pre-flow time. Adjust at the display, how long the shielding gas should flow before the welding process starts. The gas flows automatically until the welding gun is removed from the joined welding element.

- ◆ Adjust the flow meter at the gas bottle to 8 to 16 liters/min.
- ◆ Press simultaneously the two arrow keys at the power unit () for about one second.
- ◆ The display shows 1 ... 00.
- ◆ Now set the gas pre-flow time with the two arrow keys (longer – shorter).
- ◆ 01 corresponds to 100 ms, 10 to 1 s (adjustment range 0 to 2 s)
- ◆ You return to the display of welding time by another simultaneous press on the two arrow keys () for about one second.



If you are working without shielding gas, set the gas pre-flow time 1 ... 00. The gas valve remains closed during welding.

5.7 Welding Procedure



Improper operation of the stud welding unit is LIFE-THREATENING! The stud welding unit must only be operated by qualified personnel (see chapter 1). Observe the safety instructions in chapters 1, 3 and 5.

- ◆ Prepare the stud welding unit, the ground connection, and the workpiece according to the instructions given in the operating manual.



Chapter 5 contains guideline for welding parameters. The data given are only guidelines. They must be verified by trial welds on the actual workpiece according to actual standards and DVS regulations (see appendix).



During the actual welding process, you must expect red-hot welding spatters, possibly liquid spatters, a flash, and a loud bang may occur > 90dB (A). Inform any colleagues who are occupied in the vicinity of the welder about the bang.

Wear always your personal protective equipment according to actual standards (see appendix).

- ◆ Insert the welding element into the chuck.

As soon as the power unit is ready for the welding process,

- ◆ place the welding gun vertically against the workpiece,
- ◆ push the welding gun firmly with both hands onto the workpiece until the welding gun support (distance device) is evenly seated on the workpiece,
- ◆ hold the welding gun firmly, still, and straight,
- ◆ take care that you do not touch any metallic part of the welding gun,
- ◆ press the trigger button of the welding gun.

This initiates the welding process.



The welding process can only be initiated, if the current circuit is closed, i.e. the welding element is in electrical contact with the base material.



After the welding process has been completed, withdraw the welding gun straight back from the welding element. If you remove the welding gun at an angle, the chuck will be stretched, this reduces its life expectancy.

You can now insert a new welding element in the chuck and repeat the welding process as described above.

5.8 Checking the Quality of the Weld

You can check the quality of the weld by means of a visual inspection and a bending test.







See also actual standards in the appendix “Arc stud welding of metallic materials“, in section irregularities and corrective actions.

5.8.1 Visual Inspection

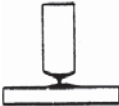
A visual inspection must be carried out with each welding element.

Shape, size, evenness, and color of the weld collar are assessed during a visual inspection. The length of a welded element should be 2 - 3 mm shorter than before welding.

Visual Inspection		
Condition	Possible cause	Corrective actions
Weld collar evenly, shiny, and complete Length of welding element within tolerance after welding 	- Correct parameters	- None
Contraction of weld collar welding element too long 	- Plunging depth or lift too low - Welding energy too high - Ceramic ring not centered correctly	- Increase plunging depth, check lift and centering of the ceramic ring - Decrease current and/or time - Check centering
Weakly developed, uneven weld collar with mat surface Welding element too long 	- Welding energy too low - Ceramic ring is humid	- Increase current and/or time - Rebake ceramic rings in a furnace
Single-sided weld collar Undercut 	- Arc blow effect - Ceramic ring not centered correctly	- See arc blow effect - Check centering
Weld collar low, shiny surface with many spatters Welding element too short 	- Welding energy too high - Plunging speed too high	- Decrease current and/or time - Adjust plunging depth and/or damping factor

5.8.2 Bending Test

You can purchase from HBS a bending device with inserts for various diameters of the welding elements.

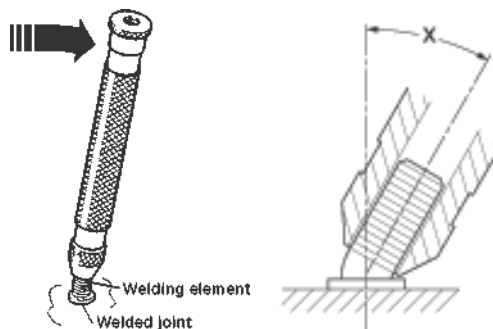

The bending test serves as an easy work sample and as a check for the selected welding parameters.

- ◆ Bend the welding element with the bending device once by 60°. Carry out the test in different directions.

The bending test is passed if a crack or a fracture of the welded zone does not occur.



- ◆ Please note the instructions on fault recognition and corrective actions in chapter 5.



You don't need to test all studs. It is sufficient to carry out stud tests at random.

If the strength of the joint is inadequate, then:

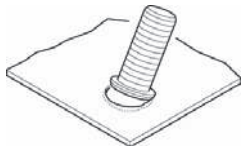
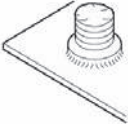
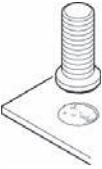
- ◆ check the setting of the stud welding unit
- ◆ check whether the surface of welding element and base material are clean and electrically conductive (must be free from scale, oil, paint, oxide layers)
- ◆ grind off hardened workpiece surfaces (e.g. roll hardening).
- ◆ Check the piston of the welding gun for ease of movement.

Bending Test		
Type of fracture	Possible cause	Corrective actions
Base material buckling 	- Correct parameters	- none
Fracture in welding element above weld collar 	- Correct parameters	- none
Fracture in the weld metal Many pores 	- Welding energy too low - Plunging speed too low - Unsuitable stud/base material combination	- Increase welding energy - Increase plunging speed - Replace welding element or workpiece
Fracture in the weld metal Shiny fracture surface 	- Welding time too short	- Increase welding time

5.8.3 Arc Blow Effect

Also called arc blow effect can occur with unproportionally distributed ground connections in relation to the base material mass, varying material distribution, or welding at the edge of a workpiece. This is an undesired deflection of the arc. It causes a single-sided melting of the stud material, increased pore formation, and undercuts in the welding area.



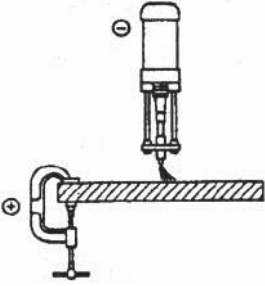
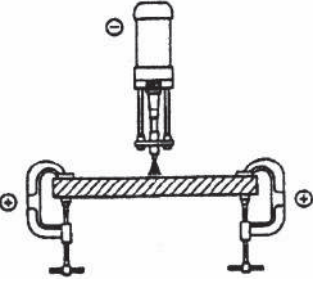
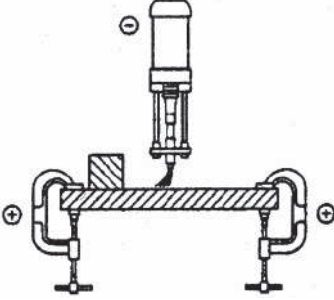
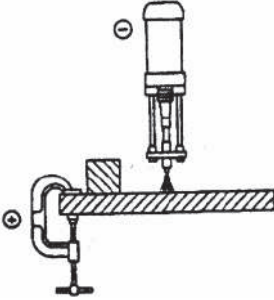
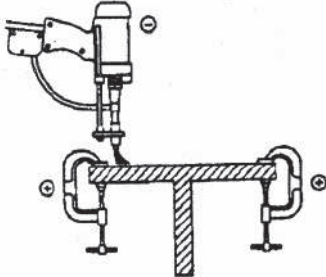
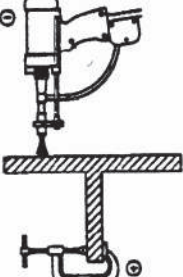

The arc blow effect is proportional to the current and can be influenced by symmetric installation of the ground clamps, by fitting of compensation masses, or by rotating the welding gun around its vertical axis (applies for welding guns with external welding cable).

Arc blow effects and some corrective actions

(according to standards, see appendix)

Cause	Corrective action
	
	
	

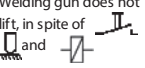
5.9 Malfunctions and Corrective Actions

Malfunction	Possible cause	Fault finding	Corrective action	Carried out by
Primary switch does not rest in position 1	Primary switch defective	Check primary switch *)	Replace primary switch *)	Qualified personnel
	Fuse F4 1 AF for primary switch defective	Check voltage supply of primary switch *)	Replace fuse F4 1 AF *)	Qualified personnel
	Primary cable defective	Check primary cable for breaks *)	Replace primary cable *)	Qualified personnel
No LED display at the front	Fuse F5 1 AF defective	Check fuse F5 1 AF *)	Replace fuse F5 1 AF *)	Qualified personnel
No K-display 	No ground connection	Check ground connection on workpiece	Tighten ground connection properly	Qualified personnel
	Welding gun not connected	Check welding gun connection	Connect welding gun properly	Instructed personnel
	Transition resistance (between stud and workpiece) too high	Check material surface	Clean or grind material surface	Instructed personnel
	Ground cable broken	Check ground cable *)	Replace ground cable *)	Qualified personnel
	Welding gun cable broken	Check welding gun cable *)	Replace welding gun cable *)	Qualified personnel
No L-display 	Defective connecting line of welding gun	Check function of connecting line *)	Replace connecting line *)	Qualified personnel
	Welding gun trigger button defective	Check control cable for electrical flow with triggered start button *)	Replace welding gun trigger button *)	Qualified personnel
	Control cable broken	Check control cable for electrical flow *)	Replace control cable *)	Qualified personnel
Continuously red display: Display 8...2	Welding sequence too fast	Power unit resets automatically	Let switched on power unit cool down, power unit resets automatically	Instructed personnel
Welding gun does not lift, in spite of  and 	No lift adjusted	Check settings of welding gun	Modify set parameters	Instructed personnel
	Short circuit of solenoid circuit of the welding gun	Check resistance value of control cable (18 Ω to 22 Ω) between Pin 1 and Pin 2 *)	Replace control cable plug, control cable, solenoid *)	Qualified personnel
	Solenoid defective Fuse F3 4 AF defective	Check solenoid (18 Ω to 22 Ω *) Check fuse F3 4 AF *)	Replace solenoid *) Replace fuse F3 4 AF *)	Qualified personnel Qualified personnel
Lifting impossible	Solenoid circuit interrupted	Check resistance value at control cable plug (18 Ω to 22 Ω) between Pin 1 and Pin 2 *)	Replace solenoid or control line *)	Qualified personnel
No shielding gas	Shielding gas not connected	Check shielding gas connection	Connect shielding gas	Instructed personnel
	Shielding gas control not enabled	Check gas control for activity	Switch on shielding gas control	Instructed personnel
	Shielding gas valve defective	Check shielding gas valve *)	Replace shielding gas valve *)	Qualified personnel



Actions marked with *) must only be carried out by qualified electricians!



Danger

If none of the actions is successful, please contact our service department.

5.10 Welding Elements

The stud welding unit must be suitable for welding the welding elements to be used. Observe the instructions in the operating manuals.

Welding elements are mainly manufactured with the cold formed process.

We recommend the following standard welding elements (see appendix).



Use only welding elements of the same lot. Take particular care not to mix-up different lots. Slightest variations in geometry of the welding elements, especially of the ignition tip, require modified settings of the welding process.

Threaded stud RD (MR)	Diameter	Length	Ceramic	Chuck Shielding gas *)
	M6	15-40 mm	83-50-006	83-51-006
	M8	15-50 mm	83-50-008	83-51-008
	M10	20-55 mm	83-50-010	83-51-010
	M12	25-60 mm	83-50-012	83-51-012
	M16	30-65 mm	83-50-016	83-51-016

Materials: S235 / St37.3k (4.8) / 1.4301, 1.4303

Threaded stud DD (MD)	Diameter	Length	Ceramic	Chuck Shielding gas *)
	M6	15-30 mm	83-50-006	83-51-006
	M8	15-50 mm	83-50-008	83-51-008
	M10	20-55 mm	83-50-010	83-51-010
	M12	25-60 mm	83-50-012	83-51-012
	M16	30-65 mm	83-50-016	---

Materials: S235 / St37.3k (4.8) / 1.4301, 1.4303

Threaded stud PD (MP)	Diameter	Length	Ceramic	Chuck Shielding gas *)
	M6	15-40 mm	83-50-006	83-51-006
	M8	20-50 mm	83-50-008	83-51-008
	M10	20-160 mm	83-50-010	83-51-010
	M12	25-160 mm	83-50-012	83-51-012
	M16	30-160 mm	83-50-016	---

Materials: S235 / St37.3k (4.8) / 1.4301, 1.4303

* Please use only welding elements without aluminum ball.

Pin UD (S)	Diameter	Length	Chuck	
			Ceramic	Shielding gas *)
	6	20-50 mm	83-50-006	83-51-006
	8	20-50 mm	83-50-008	83-51-008
	10	20-80 mm	83-50-010	83-51-010
	12	20-80 mm	83-50-012	83-51-012
	16	25-80 mm	83-50-016	---

Materials: S235 / St37.3k (4.8) / 1.4301, 1.4303

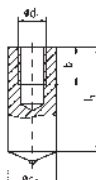
Pin with internal thread MI (ID)	Diameter	Length	Chuck	
			Ceramic	Shielding gas *)
	M10	20-50 mm	83-50-010	83-51-010
	M12	20-50 mm	83-50-012	83-51-012
	M16	20-50 mm	83-50-016	---

Materials: S235 / St37.3k (4.8) / 1.4301, 1.4303

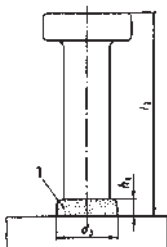
Head stud SD	Diameter	Length	Chuck ceramic
	1/4" (6)	50-100 mm	83-53-006
	3/8" (10)	50-175 mm	83-53-010
	1/2" (13)	50-175 mm	83-53-012
	5/8" (16)	50-175 mm	83-53-019
	3/4" (19)	50-175 mm	83-53-019
	7/8" (22)	75-200 mm	83-53-022

Materials: S235 / St37.3k (4.8) / 1.4301, 1.4303

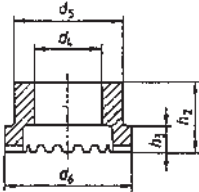
Ceramic ferrule RF for threaded stud RD	Diameter	Ceramic ferrule support
	6	80-31-095
	8	80-31-120
	10	80-31-150
	12	80-31-170
	16	80-31-205

Materials: S235 / St37.3k (4.8) / 1.4301, 1.4303

* Please use only  welding elements without aluminum ball.

- Ceramic ferrule PF for threaded stud PD Diameter Ceramic ferrule support
 - Ceramic ferrule UF for pins UD, MI

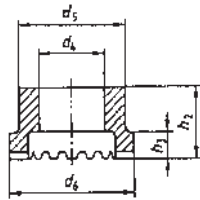

6	80-31-095
8	80-31-120
10	80-31-150
12	80-31-205
16	80-30-116

Materials: S235 / St37.3k (4.8) / 1.4301, 1.4303

Ceramic ferrule UF for head stud SD Diameter Ceramic ferrule support

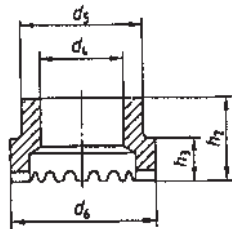

1/4"	80-30-206
3/8"	80-30-210
1/2"	80-30-213
5/8"	80-30-219
3/4"	80-30-219
7/8"	80-30-222

Materials: S235 / St37.3k (4.8) / 1.4301, 1.4303

Threaded stud FD with flange Diameter Length Chuck

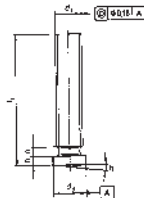

M3	on request	82-50-003
M4	on request	82-50-004
M5	on request	82-50-005
M6	on request	82-50-006
M8	on request	82-50-008

Materials: S235 / St37.3k (4.8) / 1.4301

X-mas tree stud Diameter Length Chuck



5	on request	82-50-005
6	on request	82-50-006

Materials: S235 / St37.3k (4.8) / 1.4301, 1.4303

We look forward to consult you with view to special welding elements and other special materials.

HBS Bolzenschweiss-Systeme GmbH & Co. KG
 Felix-Wankel-Strasse 18
 85221 Dachau/Germany
 Phone +49(0)8131 511-0
 Fax +49(0)8131 511-100
 E-mail post@hbs-info.com

6 Switching off the Power Unit

This chapter describes what you should observe when you switch off the power unit temporarily or completely.

6.1 Temporary Switching off

- ◆ Switch off the power unit.
- ◆ Unplug the control cable and the welding cable from the power unit.
- ◆ Protect the power unit against ingress of fluids and foreign bodies.

6.2 Disposal

If you shut down the installation, you can return the complete power unit to HBS (for address see page ii).

We will take care of environmentally correct material separation and disposal.

7 Care and Maintenance

7.1 Safety Instructions



Let maintenance and repair operations be carried out only by qualified personnel or by your competent service technician.

Before starting any repair or maintenance operation, always switch the power unit off and disconnect the primary plug.

Do not wear a wrist watch or any electrically conductive jewellery.

7.2 Regular Maintenance Operations



Clean the inner components of the power unit periodically of dust. Use a dry washcloth or a brush. To open the power unit, proceed as described in sections 7.1, 7.3 and 7.4.

- ◆ Clean the surface of the power unit with a humid washcloth and a detergent.



Do not use any solvent containing cleaning agents. Solvent containing cleaning agents may damage the surface of the power unit.

7.3 Tools to be Used

- Cross-slotted screwdriver, size 2

7.4 Open the Power Unit



Open the power unit only if you are sufficiently qualified in repairing electrical equipment.

- ◆ Remove the 10 screws of the casing (5 at each side).
- ◆ Carefully remove the cover and disconnect the ground cable on the inside of the cover.
- ◆ Now pull off the cover.

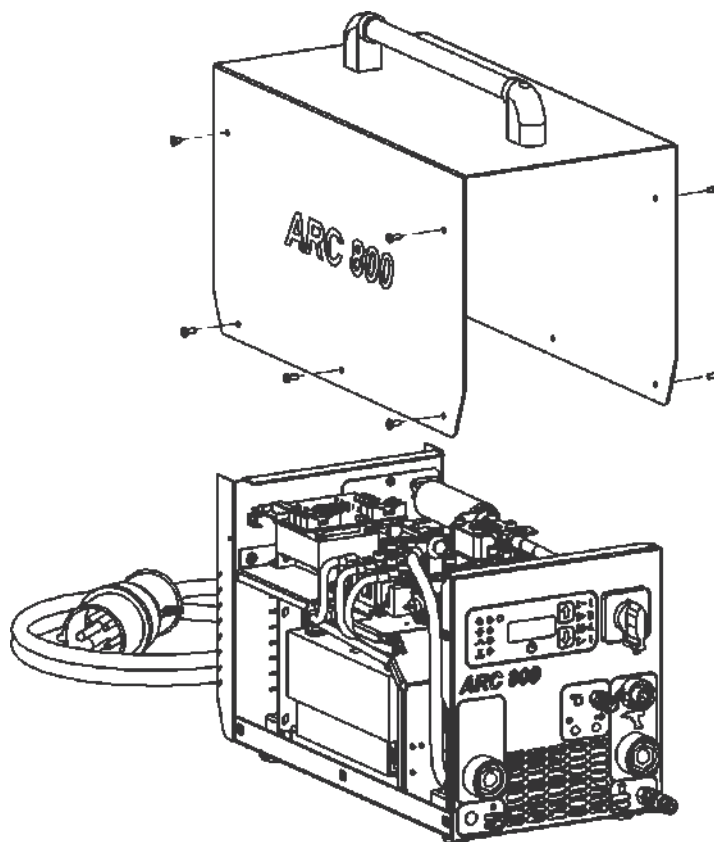

- ◆ Re-assemble the power unit in reverse sequence.



Make sure that no cables are jammed or sheared during assembly.

8 Appendix

In the appendix, there is information of interest regarding technical data, spare part lists, accessories, standards, etc.

8.1 Technical Data

Power Unit ARC 800 for ARC stud welding according to current standards

Welding range	M3 to MR12, dia. 2 to 10 mm (#4 to 1/2", dia. 14 ga to 3/8")
Welding material	Mild steel, stainless steel
Welding rate	7 to 17 studs/min (depending on application and stud dia.)
Welding current	800 A
Welding time	5 to 1,000 msec
Primary power	400 V, 3 phases, 50/60 Hz, 35 AT (alternative input voltages available)
Primary plug	32 A (at 400 V mains)
Power source	Transformer/Rectifier
Cooling type	F (temperature controlled cooling fan)
Insulation class	IP 23 (also permits operation outdoors)
Operational and storage conditions	According to current standards
Dimensions L x W x H	470 x 230 x 220 mm (without handle) (18.5" x 9.1" x 8.7")
Weight	37 kg (81 lbs)

8.2 Spare Parts

Spare part list power unit type ARC 800 (93-10-0702A)

When ordering spare parts, please indicate order number and type of power unit.

Pos.	Quantity	Order No.	Description
2	11	80-90-184	Tooth lock washer A4
5	1	88-11-386	Bottom unit complete
7	1	88-10-546	Cover plate
8	11	80-90-158	Screw M4 x 6 black
10	1	88-11-259A	Rear wall complete
11	2	80-90-149	Screw M8 x 20
12	2	80-90-150	Washer 8 mm
13	2	80-90-167	Cupal washer M8
14	2	80-10-249	Flat connection
15	1	88-11-387	Support unit complete
16	2	80-90-140	Spring washer 8 mm
17	2	80-90-141	Nut M8
20	1	88-11-268A	Front plate complete
21	1	80-10-159	Cap
22	2	80-10-115	Cap
25	1	80-10-857	Handle A=300
26	2	80-90-199	Screw M5 x 12
27	2	80-90-202	Washer 5 mm
28	2	80-90-128	Spring washer 5 mm
29	2	80-90-225	Head nut M5
30	1	88-11-272	Cover
31	10	80-90-280	Screw M4 x 10 black
32	3	80-90-296	Screw M6 x 12
33	3	80-90-147	Spring washer 6 mm
35	1	80-11-626	Label mat black
40	1	80-11-624	Label mat white
60	5 m	80-50-404	Mains cable
61	1	80-50-029	CEE plug
65	1	80-11-359	Conductor mark ground cable
85	1	93-50-020	Shielding gas module
	1	80-70-291	Cable harness

Power unit ARC 800 (93-10-0702A)

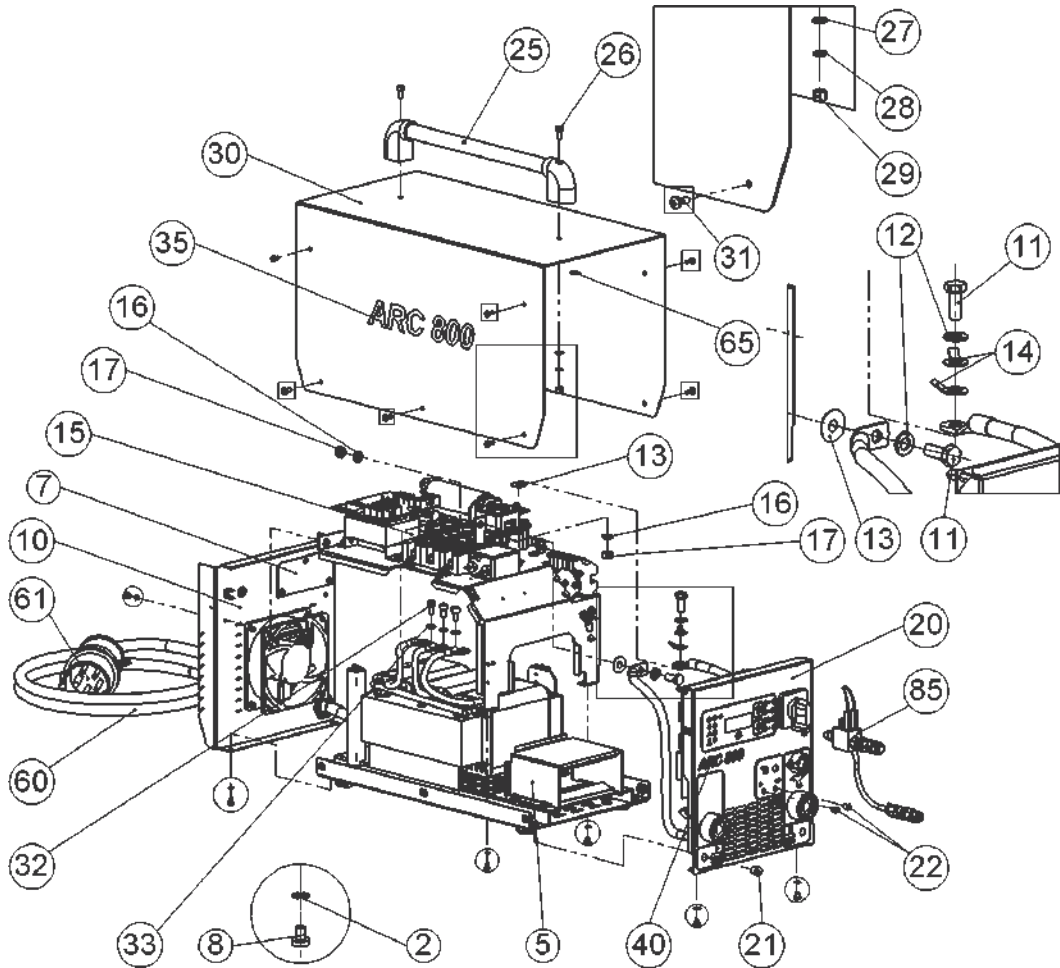

Spare part list front plate complete ARC 800 (88-11-268A)

Pos.	Quantity	OrderNo.	Description
5	1	88-11-269	Front plate
10	1	88-11-270	Boardsupport
11	2	80-90-121	Spring washer 4 mm
12	6	80-90-153	Nut M4
25	2	80-50-035	Mountingsleeve
29	2	80-90-137	Screw M3 x 8
30	1	80-30-195	Controlcablesleeve
34	4	80-90-179	Screw M4 x 12
35	1	80-50-480	Primary switch
40	2	88-11-283	Distance sleeve 6,5 x 9
45	1	80-80-497	P.C. board ARC processor (Observe program version!)*
50	2	80-11-023	Distance stud
55	1	80-80-490	P.C. board ARC supply
60	2	80-10-149	Distance stud
65	1	88-10-930A	Front film
67	4	80-10-576	Flat connection
68	2	80-56-215	Capacitor
70	1	80-70-278	Connection cable
75	1	80-70-279	Connection cable
80	2	80-11-111	Cage nut M4
85	1	80-11-754	HBS-Logosmall
90	1	80-11-359	Conductor mark ground cable

* see sticker "Controller"

Front plate complete ARC 800 (88-11-268A)

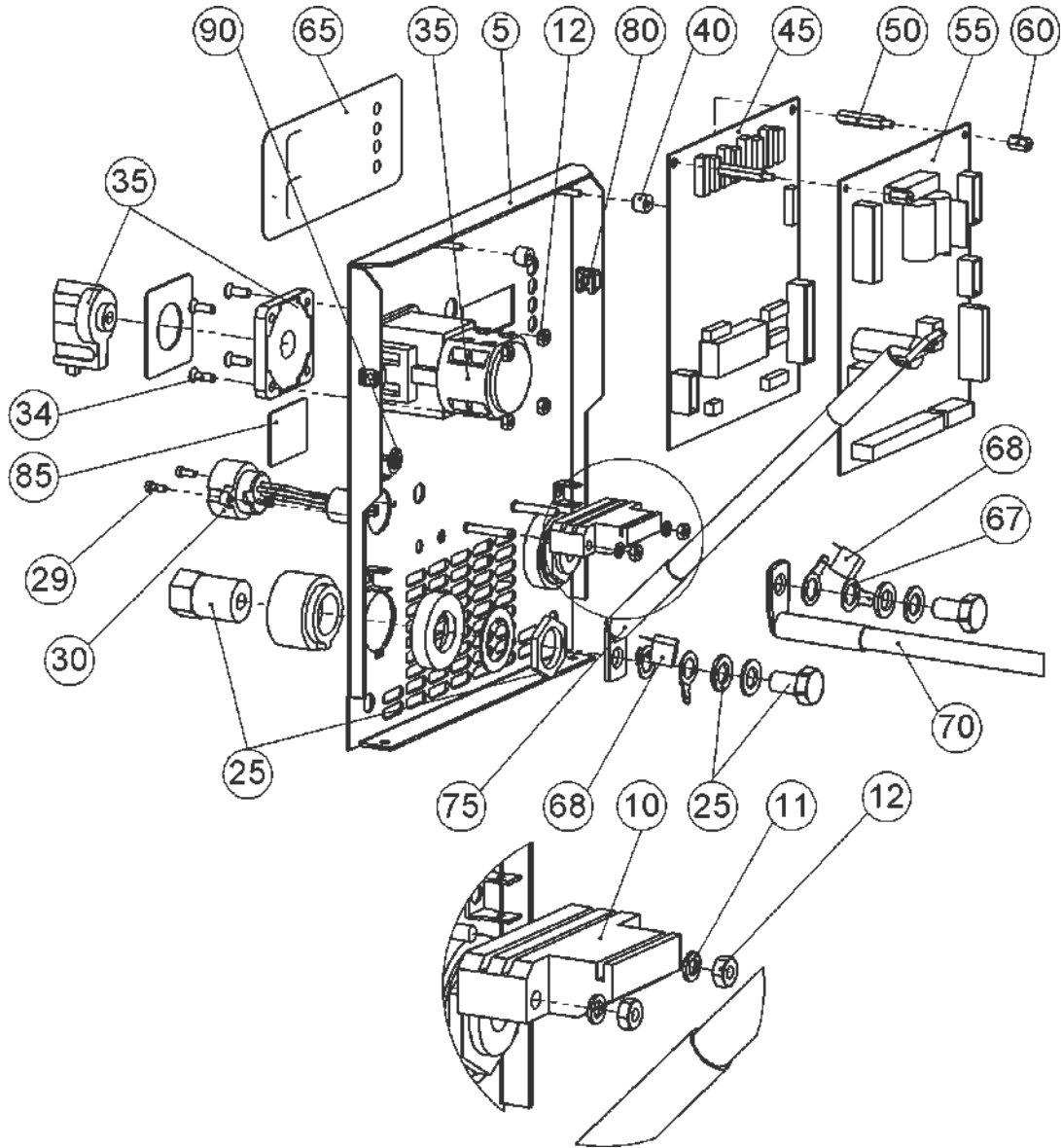

Spare part list support unit complete ARC 800 (88-11-387)

Pos.	Quantity	OrderNo.	Description
2	3	80-90-320	Screw M6 x 20
3	3	80-90-197	Tooth lock washer A6
4	6	80-90-146	Nut M6
5	1	88-11-262	Angled support plate
6	6	80-90-198	Washer 6 mm
7	7	80-90-147	Spring washer 6 mm
8	2	80-11-670	Cable mounting
9	1	80-11-669	Wire protecting sleeve
10	1	88-11-266	Angle plate
12	10	80-90-121	Spring washer 4mm
13	6	80-90-164	Washer 4 mm
25	1	80-30-262	Clamping jaw complete
35	2	80-10-785	Adhesive clip
40	1	80-11-643	Cable mounting pluggable
45	1	80-50-927	Mains interference filter
46	14	80-90-191	Screw M4 x 8
49	6	80-90-147	Spring washer 6 mm
50	1	88-11-263	Mounting plate
51	6	80-90-163	Screw M6 x 16
52	6	80-90-128	Spring washer 5 mm
53	6	80-90-198	Washer 6 mm
54	6	80-90-239	Cupal washer M6
55	3	80-55-331	Diodes-Diodes module
57	2	80-11-121	Flat connection
58	6	80-90-163	Screw M6 x 16
60	1	88-11-425	Conductor rail plus
62	4	80-90-203	Screw M6 x 12
63	2	80-11-642	Distance stud M6
65	1	88-11-424	Conductor rail minus
70	1	80-40-384	Clamping plate
75	1	80-40-383	Cupal plate
80	1	80-55-076	Thyristor
84	4	80-90-168	Screw M5 x 35
85	1	80-10-177	Clamping plate
90	1	80-56-041	Capacitor

95	1	80-57-332	Resistor L
97	2	80-90-202	Washer 5 mm
98	2	80-90-127	Screw M5 x 8
100	1	88-11-252	Transformer400V
105	1	80-80-491	P.C.board ARC transformer
110	2	80-55-021	Solid State Relay
112	2	80-70-346	Varistor
115	1	80-70-345	Varistor
120	3	80-11-359	Conductor markground cable

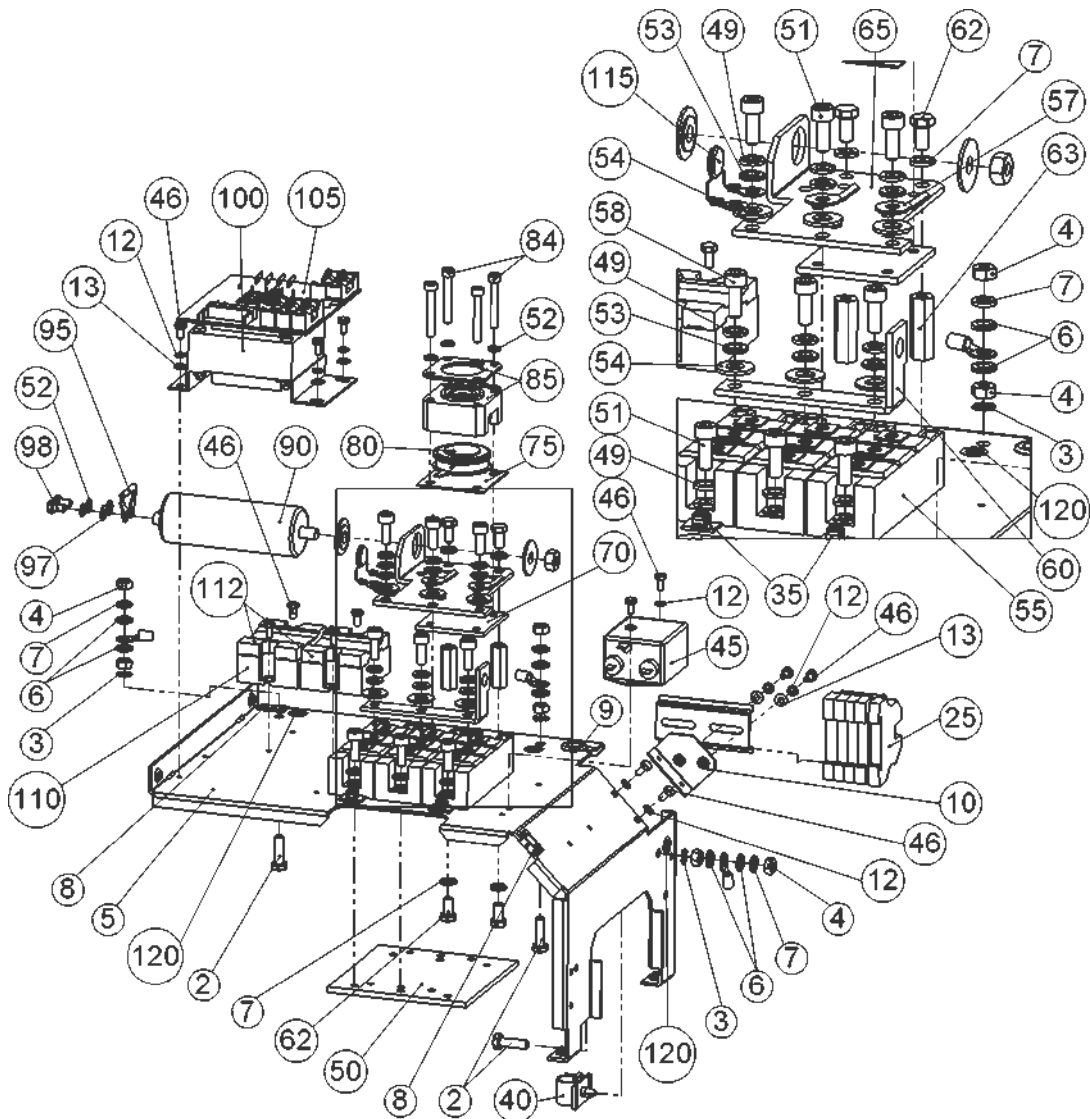

Spare part list rear wall complete ARC 800 (88-11-259A)

Pos.	Quantity	OrderNo.	Description
5	1	88-16-456	Rearwall
10	1	80-10-0960	ZEVb-Screwing
15	1	80-11-567	Lock nut
30	1	80-50-049	Fan
31	4	80-90-108	Screw M4 x 12
32	4	80-90-121	Spring washer 4 mm
33	1	80-90-184	Tooth lock washer A4
35	1	80-11-359	Conductor markground cable

Rear wall complete ARC 800 (88-11-259A)

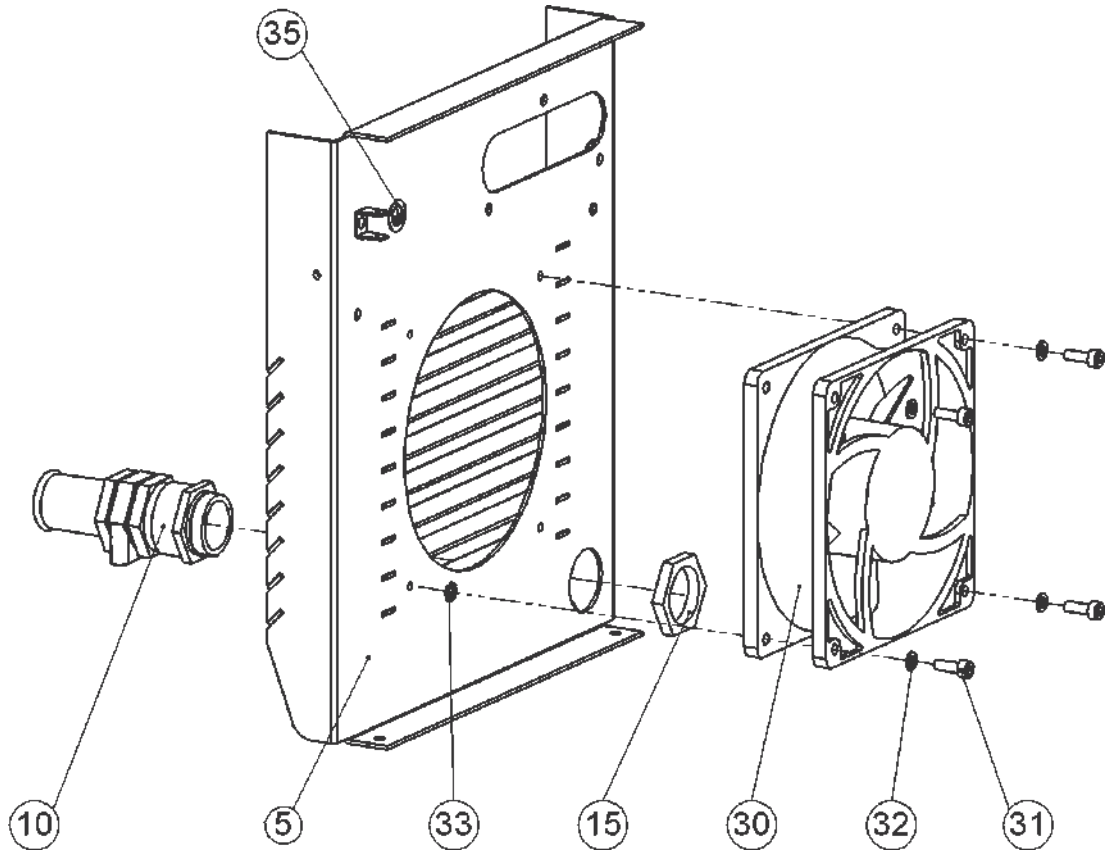

Spare part list bottom unit complete ARC 800 (88-11-386)

Pos.	Quantity	OrderNo.	Description
3	6	80-11-437	Cage nut M4
5	1	88-11-256	Bottom plate
10	4	80-10-203	Casingfeet
11	4	80-90-173	Screw M4 x 10
12	4	80-90-164	Washer 4 mm
15	1	88-11-258	Resis torsupport
16	2	80-90-152	Screw M5 x 10
17	2	80-90-128	Spring washer 5 mm
18	2	80-90-202	Washer 5 mm
20	1	80-57-041	Resistor
25	1	88-11-251	Transformer
26	4	80-90-296	Screw M6 x 12
27	4	80-90-147	Spring washer 6 mm
28	4	80-90-198	Washer 6 mm
30	1	88-11-257	U-plate
31	4	80-90-110	Screw M4 x 8
32	4	80-90-121	Spring washer 4 mm
50	1	80-11-359	Conductor markground cable

Bottom unit complete ARC 800 (88-11-386)

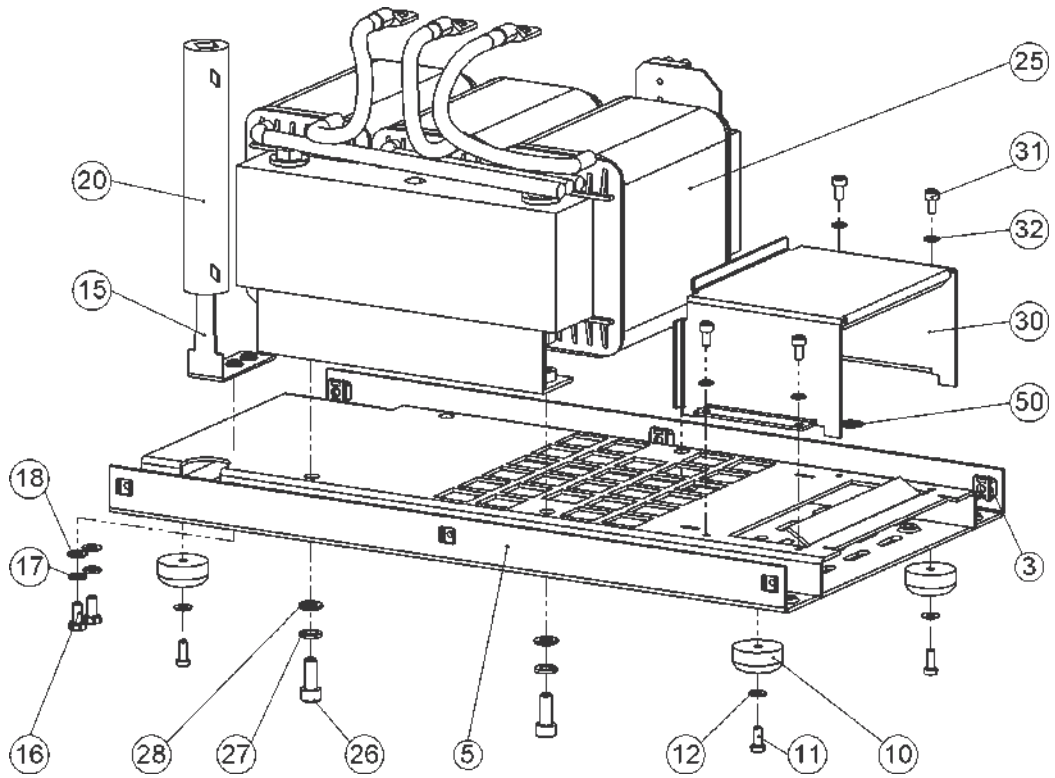

Spare part list shielding gas module ARC 800 (93-50-020)

Pos.	Quantity	OrderNo.	Description
100	1	80-10-145	Connectorfemale
110	1	80-10-024	Nipple
115	1	80-10-139	Connectormale
120	1	80-10-146A	Solenoidvalve
122	2	88-11-839	Connectioncable
125	1	80-10-143	Connectorfemale
140	0.26 m	80-10-182	Plastic hose

Shielding gas module ARC 800 (93-50-020)

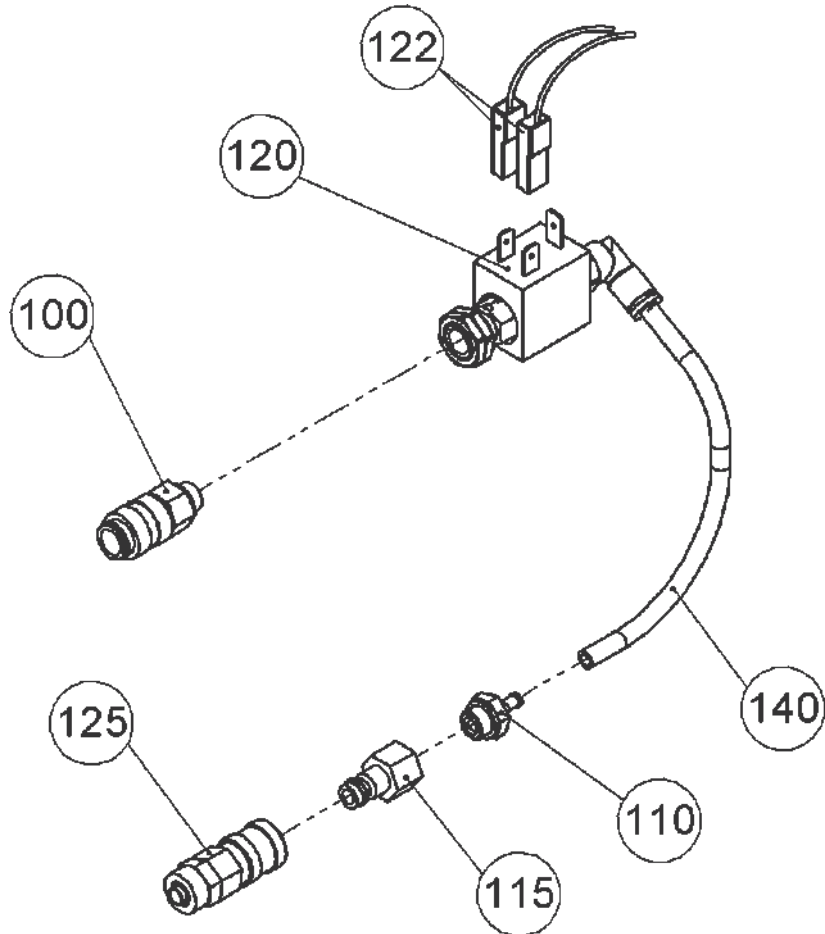

Changing the electronic board



Changing the electronic board may only be carried out by sufficiently qualified personnel or by your service technician.

Before starting any repair or maintenance operation, always switch the power unit off and disconnect the primary plug.

Do not wear a wrist watch or any electrically conductive jewellery.



To change the electronic board, proceed as described in section 7.1 (Safety Instructions), 7.3 (Tools to be Used) and 7.4 (Open the Power Unit).

Replacement of the electronic board 80-80-490

- ◆ Loosen the plugs X1, X2, X3, X4, and SV2.

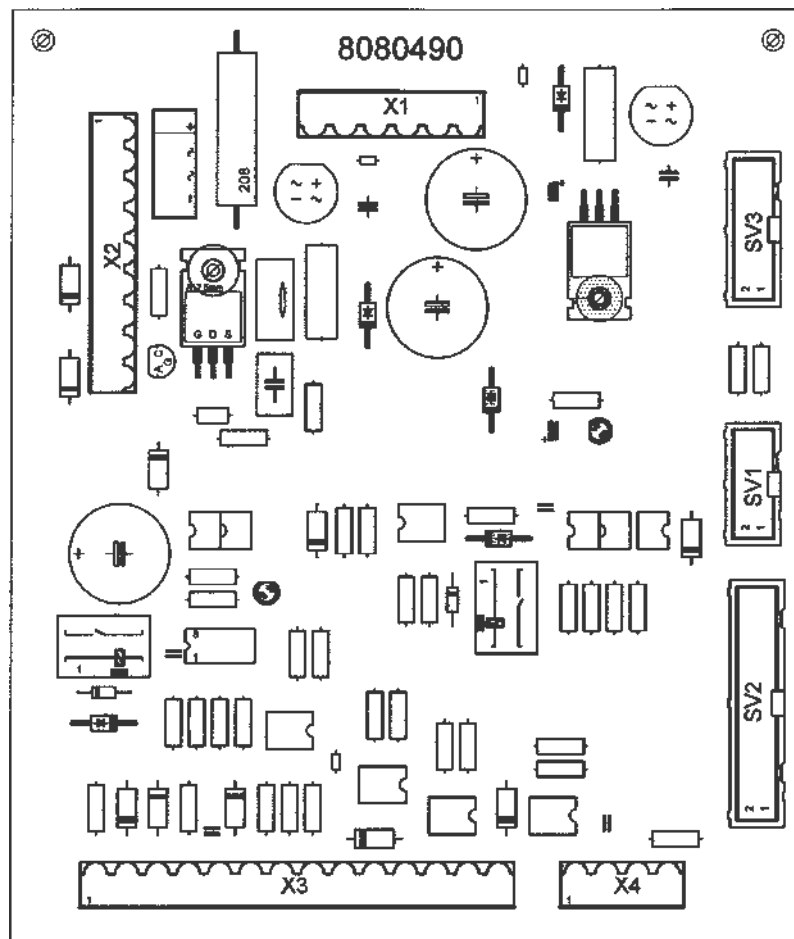

- ◆ Remove the two spacers.

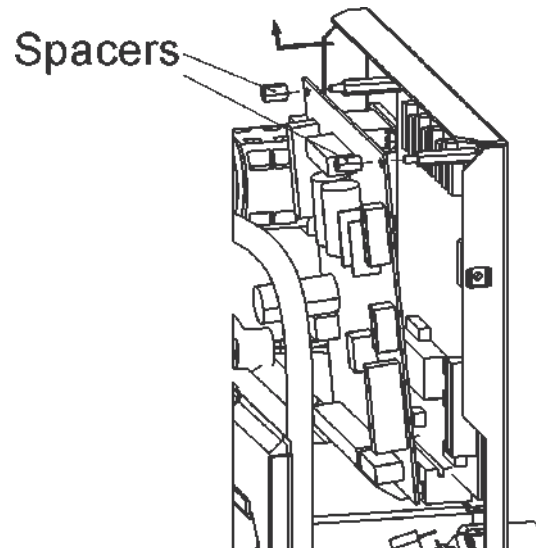

- ◆ Replace the electronic board. For re-assembly, proceed in reversed sequence.

Replacement of the electronic board 80-80-497

- ◆ See changing the electronic board 80-80-490. In addition, you must remove the two spacers.

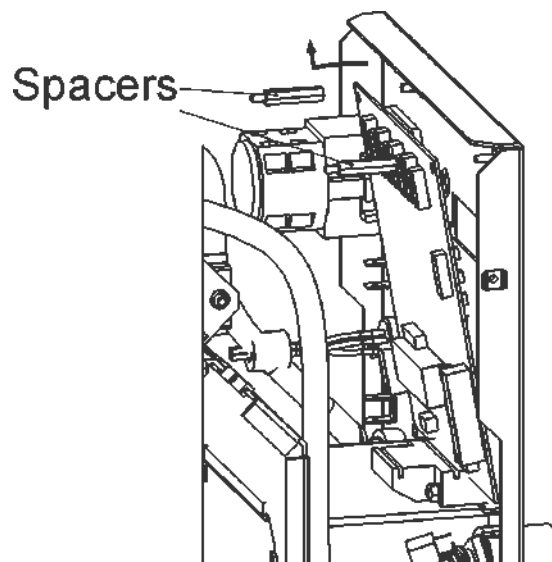

- ◆ Replace the electronic board 80-80-497.



Please observe the program version!

Main board (80-80-497)

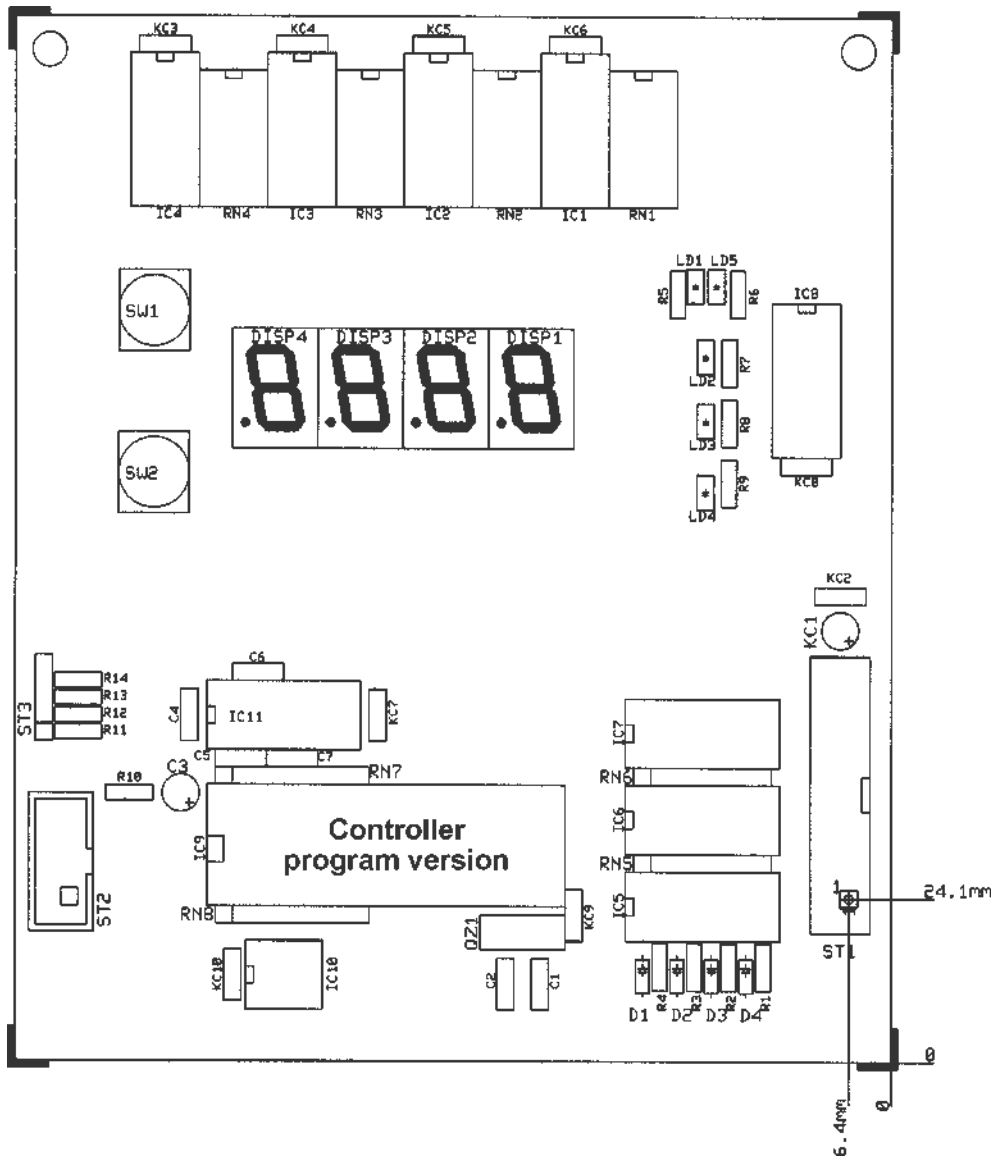

Please observe the program version!

Transformer board (80-80-491)

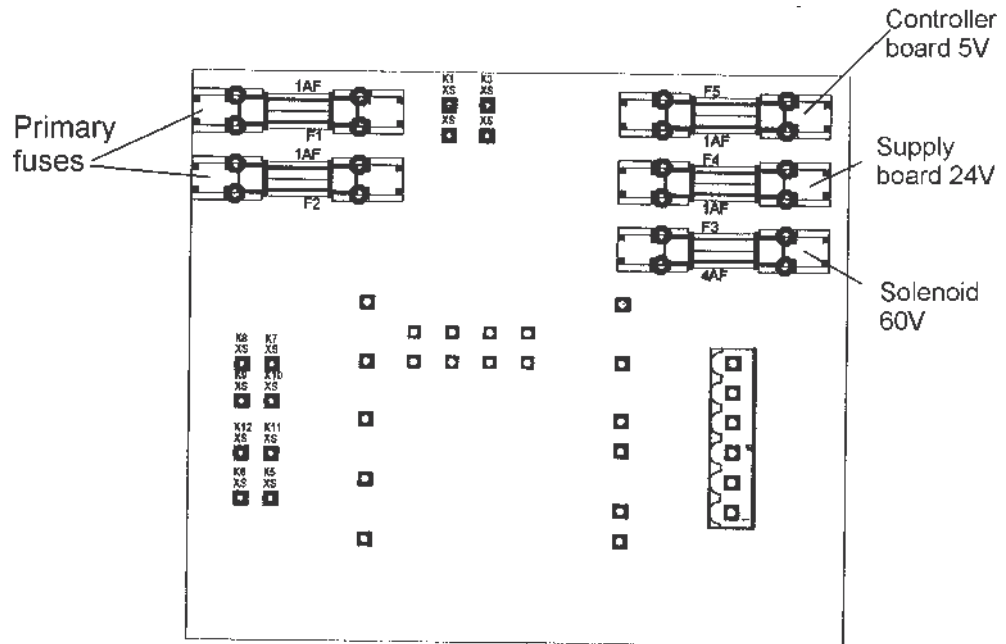

8.3 Electrical Circuit Diagram

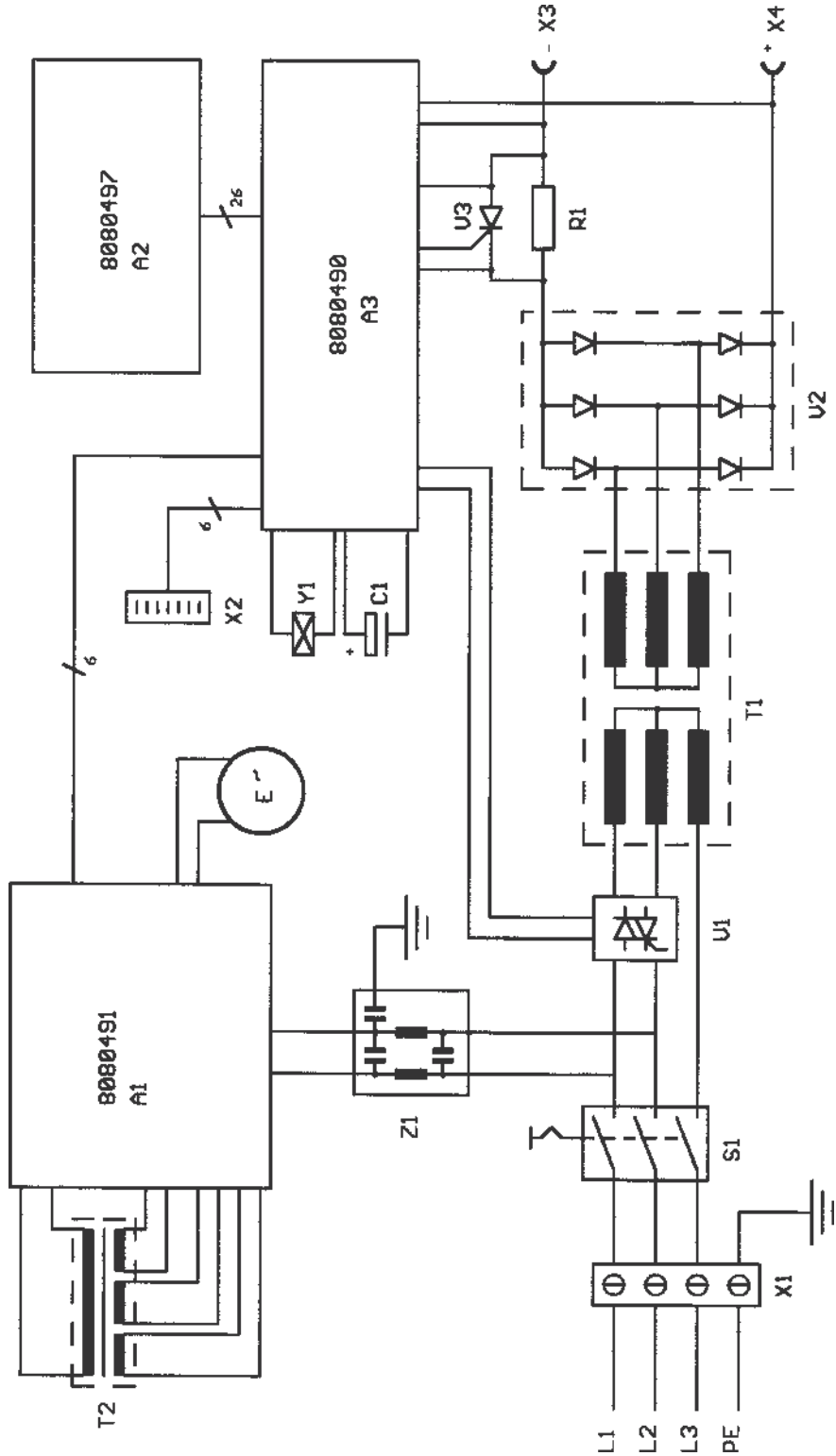

8.4 Environmentally Admissible Disposal

- ◆ After repair of the power unit, dispose replaced parts in an environmentally admissible way.

Used materials:

- Steel
- Nonferrous metals (brass, copper)
- Plastics
- Aluminum

Glossary

Arc:	Electrical discharge at its own between two electrodes under sufficiently high current. Whitish light is emitted. The arc generates very high temperatures.
Automatic welding head:	Device to weld welding elements
Capacitor:	A component which serves as storage of electrical charge
Power unit:	Device to provide electrical energy for stud welding
Rectifier:	Electric component transforming alternating current into direct current
Stud feeder:	Device for the automatic stud feeding of welding elements
Stud welding unit:	Power unit inclusive welding gun
Thyristor:	Electronic component, contactless switch, which will let the current only pass through if a control pulse is given to the gate (additional electrode)
Welding element:	A component, like a stud, bolt, pin, which is welded to the work piece
Welding gun:	Device to weld welding elements
Welding parameters:	Various settings on the gun as well as on the power unit. For example: duration and strength of current during welding process, charging voltage, spring force of the welding gun.
Work piece:	A component, like a sheet, tube, etc. to which the welding element is fastened

Regulations and Standards

The regulations and standards are recommendations and don't purport to be completely.

Standards, regulations	Description
<u>Studwelding (fundamentals)</u>	
DIN EN ISO 13918	Welding - Studs and ceramic ferrules for arc stud welding
DIN EN ISO 14555	Welding - Arc stud welding of metallic materials
DIN EN 1418	Welding personnel - Approval testing of welding operators for fusion welding and resistance weld setters for fully mechanized and automatic welding of metallic materials
DVS 0901	Stud welding method for metals - Survey
DVS 0902	Arc stud welding
DVS 0903	Capacitor discharge welding with tip ignition
DVS 0904	Tips - Arc stud welding
DVS 2927	Resistor projection welding and Arc welding of one-sided thick plastics coated thin metal sheets
<u>Studwelding (general)</u>	
DIN EN ISO 4063	Welding and allied processes - Nomenclature of processes and reference numbers
DIN ISO 857-1	Welding and allied processes - Vocabulary - Part 1: Metal welding processes
DIN EN ISO 14175	Welding consumables - Shielding gases for fusion welding and allied processes
DIN EN 764-1	Pressure equipment - Part 1: Terminology - Pressure, temperature, volume, nominal width
DIN EN 6947	Welds - Working positions - Definitions of angles of slope and rotation
DIN 1910	Welding

Machine safety

73/23/EWG	Electrical equipment designed for use within certain voltage limits
2004/108/EG	EMC-Guidelines
98/37/EG	Machineguidelines
DINEN60204-1	Safety of machinery - Electrical equipment of machines - Part 1: General requirements
DINEN60529	Degrees of protection provided by enclosures (IP code)
DINEN60974-1	Arc welding equipment - Part 1: Welding power sources
DINEN60974-10	Electromagnetic compatibility (EMC); Arc welding equipment - Part 10: Requirements

Personal safety and accident prevention

DINEN ISO 20345	Personal protective equipment: Safety footwear
DINEN 12477	Protective gloves for welders
DINEN 166	Personal eye-protection - Specifications
DINEN 352-1	Hearing protectors - General requirements - Part 1: Ear-muffs
BGV A1	Safety rules „Principles of prevention“
BGV A3	Accident prevention regulation „Electrical equipment and operating material“
BGV B3	Safety rules “Noise”
BGV B11	Safety rules “EMC”
BGV D1	Safety rules - welding, cutting and similar processes



Please note that in your country additional standards and safety conditions (especially rules for accident prevention) may differ from the standards mentioned in this operating manual.

Further Instructions

Welding elements, abbreviations, materials, standards, mechanical properties to actual standards

Stud types		Abbreviations for studs (ceramic ferrules)	Material	Norm	Mechanical characteristics	
Stud welding with drawn arc (DS)	Drawn arc welding with ceramic ferrule (CF) or shielding gas (SG)	Threaded stud	PD (PF)	Mild steel (4.8 ¹⁾)	ISO 898-1	see ISO 898-1
		Threaded stud with reduced shaft	RD (RF)			
		Pin	UD (UF)	1.4301/03 (A2-50)	EN ISO 3506-1	see ISO 3506-1
		Pin with internal thread	ID (UF)			
	Head stud	SD (UF)	Mild steel (S235J2G3 + C450)	ISO/TR 15608	Rm ≥ 400 N/mm ² ReH ≥ 235 N/mm ² A5 ≥ 15%	
			1.4301/03 (A2-50)	EN 10088-1	Rm ≥ 500 - 780 N/mm ² Rp0,2 ≥ 350 N/mm ² A5 ≥ 25%	
	Short cycle welding with drawn arc	Threaded stud with flange	PS	Mild steel (4.8 ¹⁾) copper plated	ISO 898-1	see ISO 898-1
		Pin with flange	US			
		Pin with internal thread and flange	IS	1.4301/03 (A2-50)	EN ISO 3506-1	see ISO 3506-1

Further materials on request

¹⁾ weldable

Prestress at installation (tie load) and torque

Threaded stud	Steel (4.8 ¹⁾) μ = 0,18 R _{p0,2} = 340 N/mm ²		1.4301/03 (A2-50) μ = 0,18 R _{p0,2} = 210 N/mm ²		AlMg3 (F23) μ = 0,18 R _{p0,2} = 170 N/mm ²		CuZn37 (Ms63) μ = 0,18 R _{p0,2} = 250 N/mm ²	
	Prestress at installation (kN)	Torque (Nm)	Prestress at installation (kN)	Torque (Nm)	Prestress at installation (kN)	Torque (Nm)	Prestress at installation (kN)	Torque (Nm)
M6	4,3	6,1	2,7	3,8	2,2	3,1	3,2	4,5
M8	8,0	15,0	4,9	9,5	4,0	7,5	6,0	11,0
M10	13,0	30,0	7,8	19,0				
M12	19,0	53,0	12,0	33,0				
M16	35,0	135,0	22,0	82,0				

Values correspond with actual standards

¹⁾ weldable

All given values are leads for minimum tensile strength and minimum torque of a weld without permanent deformation of parts to be joined. Parts to be joined must have sufficient wall thickness. Values apply for cold rolled threaded studs with standard thread without surface protection and without thread lubrication. Throughout the entire stud length, at least the stressed cross section must be present. Values apply for indicated yield strengths.

Material combinations

according to the actual standards (select stud material in a way that material of the same kind is welded).

Stud material	Base material			
	ISO/TR 15608 Groups 1 and 2.1	ISO/TR 15608 Groups 2.2, 3 to 6	ISO/TR 15608 Groups 8 and 10	ISO/TR 15608 Groups 21 and 22
Steel (S235) 4.8 ¹⁾ 16Mo3	a	b	b	--
1.4301/03, 1.4401/04, 1.4541, 1.4571	b/a	b	a	--
EN AW-AlMg3/EN AW-5754	--	--	--	b
EN AW-AlMg5/EN AW-5019	--	--	--	b

Exemplification of welding suitability
 -- non weldable
 a well suited for any application, e.g. power transmission
 b suitable, limitations with power transmission

Weldability tests of other material combinations upon request.

¹⁾ weldable

Guarantee Clauses

Please refer to the current "General Terms and Conditions" for the guarantee clauses.

We are not liable for malfunctions which are caused by

- normal wear,
- improper use,
- non-observing the operating manual,
- transport damages.

Any guarantee claim will be cancelled if repair operations are carried out by unauthorized persons.



Danger

Warning: Unauthorized interference with the stud welding unit as well as unauthorized alteration of the stud welding unit are prohibited and result in complete cancellation of any guarantee and liability claims against HBS.

Please fill in the serial number:

Serial number automatic welding head:

Serial number power unit:

Serial number welding gun:

Serial number stud feeder:

Please indicate the serial numbers in case of enquiries or when ordering spare parts.

EU-Statement of Conformity

Manufacturer: HBS Bolzenschweiss-Systeme GmbH & Co. KG
Felix-Wankel-Strasse 18
Postfach 13 46
85221 Dachau / Germany
Phone +49 (0) 8131 511-0
Fax +49 (0) 8131 511-100

Statement: This is to certify, that equipment listed below is designed and manufactured in conformance to the safety and health regulations.
This statement is invalid if any modifications are done on the equipment without prior written approval by HBS.

Description of equipment: Power Unit
Type: ARC 800
Order No: 93-10-0702A
Serial-No:

Applicable EG-guidelines and corresponding standards:

- Low voltage guideline 73/23/EWG:
DIN EN 60204-1 Safety of machinery - Electrical equipment of machines - Part 1: General requirements
 - EMC guidelines 2004/108/EG:
DIN EN 60974-10 Electromagnetic compatibility (EMC) - Arc welding equipment - Part 10: Requirements
 - Machine guidelines 98/37/EG:
DIN EN 60974-1 Arc welding equipment - Part 1: Welding power sources
-



Date

Signature (General Manager HBS)

Confirmation

Herewith I confirm that I have read and understand the present operating manual completely.

Date

Name

_____	_____
_____	_____
_____	_____
_____	_____
_____	_____
_____	_____
_____	_____
_____	_____
_____	_____
_____	_____
_____	_____
_____	_____
_____	_____
_____	_____
_____	_____
_____	_____
_____	_____
_____	_____
_____	_____
_____	_____
_____	_____
_____	_____
_____	_____
_____	_____

Feedback

**HBS Bolzenschweiss-Systeme
GmbH & Co. KG
Felix-Wankel-Strasse 18
85221 Dachau / Germany
Postfach 13 46
85203 Dachau / Germany**

Sender:

**Product description
Serial number**

My opinion/criticism/complaints/indication of malfunction:

Date and signature _____

Service & Support

With the sending please attach a copy of the filled out form together with the repair number given by HBS!
Repairs without repair number will not be handled.

Repair number
(given by HBS)

Company: _____
 Name / Surname: _____
 Street: _____
 City, State and ZIP: _____
 Country: _____
 Phone & Fax: _____
 E-mail address: _____
 Unit / gun type of model: _____
 Serial number: _____
 Date of purchase: _____
 Purchased at distributor: _____

Further descriptions of default:	_____

Service & support may be done up to the value of EUR _____
 without tender: Yes No

Could you find any damage / burning mark:
 on the cables: Yes No
 on chucks: Yes No











Are all plug and screw connections fastened tight *: Yes No

Are there any burning marks on plug or screw connections: Yes No

Are there any other visual damages (e.g. cracks, dents): Yes No

Have you checked the fuses: Yes No

Default on the display of the power unit:

ARC					CD					
										

Which LEDs are burning (please mark with a cross)?

Please e-mail or fax this form to post@hbs-info.de or fax: ++49 - 81 31 - 5 11 - 1 00.
 In case a repair is necessary you get the required repair number!

- * See also according operating manual, chapter „Starting-up“
- ** Doesn't light when using a contact welding gun

Index

A

accident prevention	12, 24
accident prevention regulations	16
accidents	25
accompanying documents	13
airborne particles	16
arc	64
arc blow effect	37
arrow keys	33
articles, combustible	16
automatic welding head	64

B

bang	17, 25, 34
bending device with inserts	35
bending test	35
blow-up	24

C

capacitor	59
capacitor	64
care and maintenance	10
ceramic ferrule/ring	28
cold formed process	39
company specific	
maintenance instruction	9
company specific work order	9
components of the power unit	21
confirmation	70
confirmation, operator sign	9
control cable connector	18
cooling fan	45
corrective actions	36
cover	44
cross-slotted screwdriver	43

D

defective cables	30
delivery	10, 15
display	22
disposal	42
disposal, environmentally admissible	63
distance device	34
drawn-arc stud welding, variations	27
DVS regulations	33

E

ear protection	9, 24
electrical circuit diagram	62
electrical shock, risk of	18
electrical voltage	11, 14
electromagnetic fields	11
electronic board	58
entire plug connection, destroying	18

F

fault recognition	36
feedback	71
fire extinguisher	16, 24
fire risk	24
flash	17, 25, 34
fluids, ingress of	42
foreign bodies, ingress of	42
fume extraction	24
function	21
functional principle	10
further instructions	67
fuse rating	17

G

gas pre-flow time	33
general	9
general safety instructions	12
glossary	64
gloves	9
ground cable	19
ground clamps	19
ground connection	19, 44
guarantee claims	12, 25, 68
guarantee clauses	68
guide	10

H

headgear, protective	24
heat built-up	16
high-strength welds	30
hollow parts, welding on	24

I

intended use	12
--------------	----

K

keyboard	22
----------	----

L

liability, any 12, 25, 68
 liquid spatters 34
 liquids, combustible 16
 locked 22
 lot 39

M

magnetic fields 16, 25
 mains switch 32
 maintenance 9, 43
 maintenance instruction 9
 maintenance instruction
 for your company 9
 malfunction 9
 malfunctions and corrective actions 38
 markings 14
 material combinations 31, 67
 material of the welding element 30
 material of the workpiece 30
 material separation,
 environmentally correct 42
 metal spatters 24
 minimum flow rate 20

N

non-combustible clothes 24

O

operating manual 9, 15
 operating manual, storage of 9
 operation, improper 33
 operators 9
 order number 46
 ordering spare parts 68

P

pace maker 11, 17, 25
 personal injury 11
 personnel, properly instructed, qualified ... 9
 personnel, qualified 9
 pipes, welding to 30
 place of operation 12
 power unit 21, 64
 prestress at installation 31, 67
 primary power supply 17

production 9
 program version 48, 59, 60
 protective apron 24
 protective equipment 17, 25
 protective equipment, personal 9
 protective gloves 24
 protective goggles 9
 punched plates 30
 punched plates, welding to 30

R

ready for welding 22
 rectifier 21, 64
 recycling 63
 regulations 65
 repair 63
 requirements of workplace 16
 risk of material damage 11
 room adequately ventilated 16, 24
 rooms exposed to risk of explosion 16

S

safety goggles 24
 safety instructions 9, 23, 43
 safety symbols 11
 serial number 68
 service 9
 service & support 72
 service technician 9
 set-up 9
 shielding gas connection 20
 shielding gas module 56
 shoes 9
 solid-state-relais 21
 spare parts, ordering of 46, 68
 special welding elements 41
 standards 65
 standards, actual 12, 33
 starting-up 10, 16
 stud feeder 64
 stud welding, functional principle 26
 stud welding procedure 23
 stud welding process 10
 stud welding unit 64
 surface of welding element 36
 surface, workpiece 36
 switching off, temporary 42
 switching off the power unit 10, 42

T

technical data	10, 45
test welding	30
threat to life	10
thyristor	64
torque	31, 67
training according to current standards	9
transformer	21
transformer board	61
transportation	9
transportation, packaging, storage	13
type plate	14, 17

U

unauthorized use	9
------------------------	---

V

vapors, toxic	16
visual inspection	35

W

weld, checking the quality of the	34
welding elements	12, 31, 39, 64
welding elements, lot of	31
welding gun ..	12, 64
welding gun cables	18
welding gun support (distance device) ...	34
welding parameters	33, 64
welding parameters, determination	30
welding preparation	30
welding procedure	33
welding process	10
welding spatters	34
work piece	64
working place, change of	20



HBS Bolzenschweiss-Systeme GmbH & Co. KG • Felix-Wankel-Strasse 18 • 85221 Dachau / Germany
Phone +49 (0) 8131 511-0 • Fax +49 (0) 8131 511-100 • E-mail post@hbs-info.com

www.hbs-info.com